

SUBMITTAL INFORMATION

SERIES 800 BRASS HINGED SADDLE FOR C900 PVC PIPE

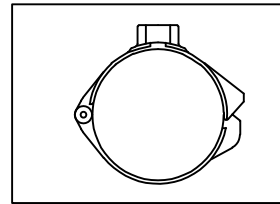

BRASS HINGED SADDLES FOR C900 (CIOD) PVC PIPE WITH AWWA (CC) AND FIP OUTLET

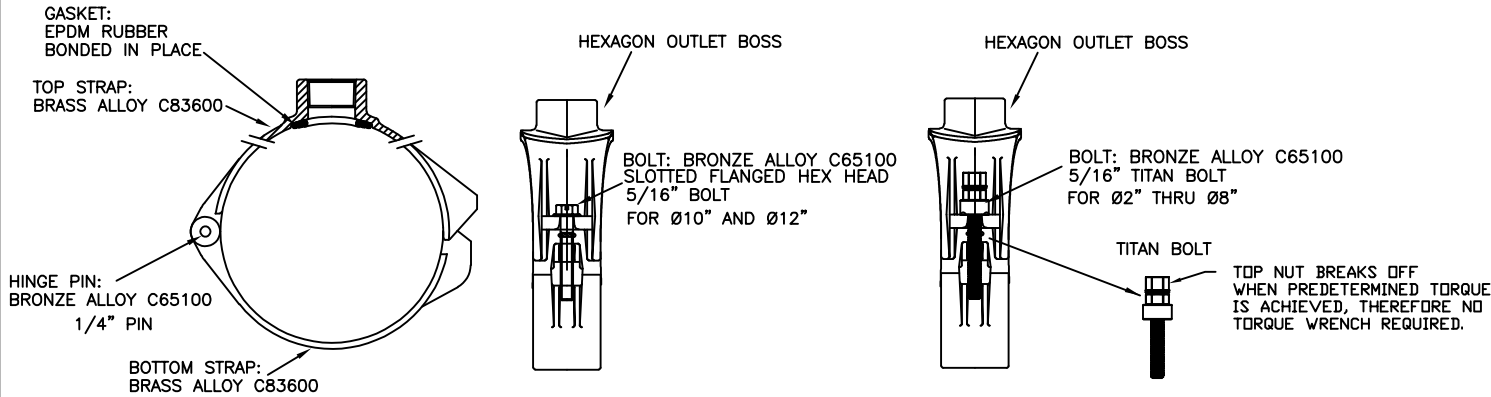

FEATURES:
 MANUFACTURED IN COMPLIANCE WITH AWWA STANDARD C800.
 COMPLIES WITH ASTM B-62 & ASTM B-584, UNS NO C83600-85-5-5-5
 PRESSURE CAPABILITIES ARE EQUAL TO, BUT DO NOT EXCEED THE WORKING
 PRESSURE RATING OF THE PIPE, UP TO 200 PSI

PVC PIPE SIZE	ACTUAL O.D.	AWWA OUTLET	CATALOG NUMBER	APPROX. WT. LBS.	SUBMITTED ITEM(S)
4"	4.80"	3/4"	800-0480-A3	3.4	
		1"	800-0480-A4	3.4	
		1 1/2"	800-0480-A6	7.3	
		2"	800-0480-A7	6.7	
6"	6.90"	1/2"	800-0690-A1	4.1	
		3/4"	800-0690-A3	4.2	
		1"	800-0690-A4	4.2	
		1 1/2"	800-0690-A6	7.8	
8"	9.05"	2"	800-0690-A7	7.2	
		3/4"	800-0905-A3	5.3	
		1"	800-0905-A4	5.1	
		1 1/2"	800-0905-A6	9.7	
10"	11.10"	2"	800-0905-A7	9.1	
		3/4"	805-1110-A3	9.3	
		1"	805-1110-A4	9.2	
		1 1/2"	805-1110-A6	14.7	
12"	13.20"	2"	805-1110-A7	14.1	
		3/4"	805-1320-A3	10.1	
		1"	805-1320-A4	10.0	
		1 1/2"	805-1320-A6	16.9	
		2"	805-1320-A7	16.3	

PVC PIPE SIZE	ACTUAL O.D.	FIP OUTLET	CATALOG NUMBER	APPROX. WT. LBS.	SUBMITTED ITEM(S)
4"	4.80"	3/4"	800-0480-F3	3.5	
		1"	800-0480-F4	3.5	
		1 1/2"	800-0480-F6	7.4	
		2"	800-0480-F7	7.0	
6"	6.90"	1/2"	800-0690-F1	4.4	
		3/4"	800-0690-F3	4.5	
		1"	800-0690-F4	4.5	
		1 1/2"	800-0690-F6	7.9	
8"	9.05"	2"	800-0690-F7	7.5	
		3/4"	800-0905-F3	5.4	
		1"	800-0905-F4	5.1	
		1 1/2"	800-0905-F6	9.8	
10"	11.10"	2"	800-0905-F7	9.4	
		3/4"	805-1110-F3	9.3	
		1"	805-1110-F4	9.2	
		1 1/2"	805-1110-F6	14.8	
12"	13.20"	2"	805-1110-F7	14.4	
		3/4"	805-1320-F3	10.1	
		1"	805-1320-F4	10.0	
		1 1/2"	805-1320-F6	17.0	
		2"	805-1320-F7	16.6	

Cambridge Brass considers the information in this submittal form to be correct at the time of publication. Item and option availability, including specifications, are subject to change without notice.

Cambridge Brass
 P.O. Box 249, 140 Orion Place
 Cambridge, Ontario
 Canada N1R 5V1
 Tel: (519) 621-5520
 Fax: (519) 621-8674
<http://www.cambridgebrass.com>



SUBMITTED BY: