

Cambridge Brass
P.O. Box 249
140 Orion Place
Cambridge, Ontario
Canada N1R 5V1
Tel: (519) 621-5520
Fax: (519) 621-8674
http://www.cambridgebrass.com

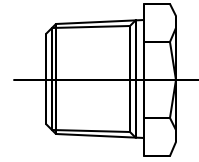

MODEL NO. 83NL

MALE IRON PIPE THREAD x
FEMALE IRON PIPE THREAD

BRASS BUSHING
FOR CORPORATION STOPS

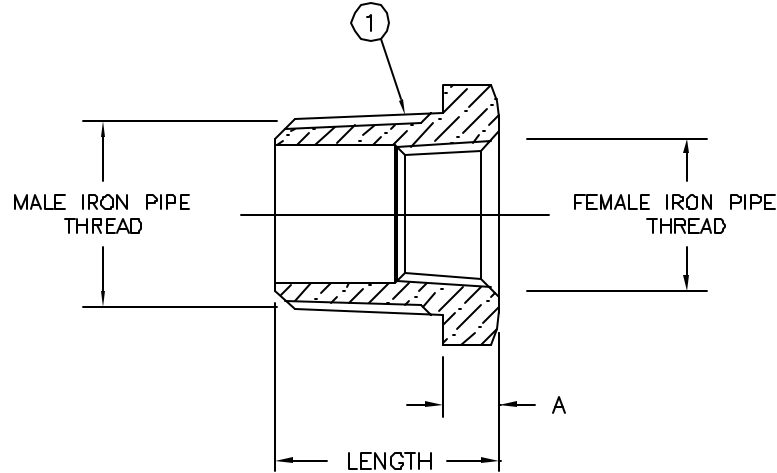

PARTS AND MATERIAL:
1. BUSHING: CAST BRASS, COPPER ALLOY C89833

FEATURES:
- MANUFACTURED IN COMPLIANCE WITH AWWA STANDARD C800 (ASTM B-584, UNS NO C89833).
- BODY PROVIDES WRENCH FLATES FOR PROPER INSTALLATION.

Cambridge Brass considers the information in this submittal form to be correct at the time of publication. Item and option availability, including specifications, are subject to change without notice.

| CATALOG NO. | OUTSIDE THREAD SIZE | INSIDE THREAD SIZE | LENGTH | WRENCH FLAT HEIGHT (A) | APPROX. WT. LBS. |
|-------------|---------------------|--------------------|--------|------------------------|------------------|
| 83NL-M4F3 | 1" MIP | 3/4" FIP | 1.05" | .24" | |
| 83NL-M5F4 | 1 1/4" MIP | 1" FIP | 2.01" | .50" | |
| 83NL-M6F4 | 1 1/2" MIP | 1" FIP | 2.13" | .50" | |
| 83NL-M7F4 | 2" MIP | 1" FIP | 2.22" | .50" | |
| 83NL-M7F6 | 2" MIP | 1 1/2" FIP | 2.22" | .50" | |

Submitted by: