

# SUBMITTAL INFORMATION

**CORNER SETTER 7020NL-XHXHX**

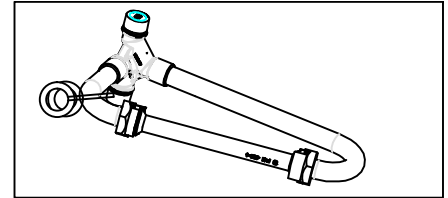

CORNER SETTER CB COMPRESSION X CB COMPRESSION

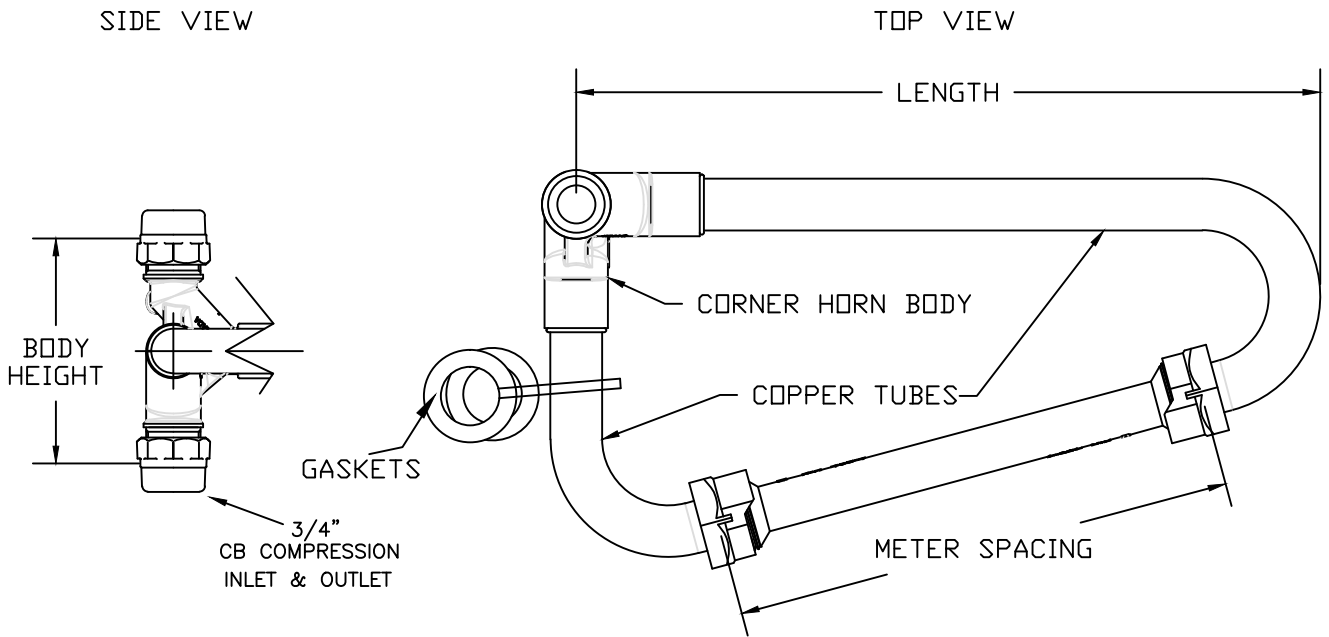

## CORNER SETTER CATALOG NUMBERS

CATALOG NUMBER	METER SIZE	METER SPACING	LENGTH	BODY HEIGHT	COPPER SIZE (O.D)	INLET SIZE	OUTLET SIZE	APPROX. WT. LBS.
7020NL-2H3H3	5/8" x 3/4"	7.82"	11 5/8"	3 7/8"	13/16"	3/4" CB	3/4" CB	

### FEATURES:

- ALL COMPONENTS CONFORM TO AWWA C800-05 (ASTM B-584, UNS NO C89833 FOR BRASS PARTS IN CONTACT WITH POTABLE WATER, AND ASTM B-62 AND B-584, UNS NO C83600 FOR ALL OTHER BRASS PARTS).
- SADDLE NUTS HOLD THE METER IN PLACE FOR TIGHTENING.
- 13/16" O.D. COPPER RISERS PROVIDE MORE FLOW CAPACITY.
- ASSEMBLED WITH LEAD FREE SOLDER.
- CONSTRUCTED WITH TYPE K COPPER TUBING, ALLOY C12200 MANUFACTURED TO ASTM 88.
- FACTORY TESTED AT 90 PSI AIR PRESSURE UNDER WATER.
- POSITIONS THE METER DIRECTLY ABOVE THE CENTERLINE OF THE SERVICE.
- THREAD PROTECTORS ARE STANDARD
- METER IDLER BAR STANDARD
- FURNISHED WITH TWO NITRILE RUBBER GASKETS FOR METER NUTS

Cambridge Brass considers the information in this submittal form to be correct at the time of publication. Item and option availability, including specifications, are subject to change without notice.

Cambridge Brass  
 P.O. Box 249, 140 Orion Place  
 Cambridge, Ontario  
 Canada N1R 5V1  
 Tel: (519) 621-5520  
 Fax: (519) 621-8674  
<http://www.cambridgebrass.com>



REV. B - FEBRUARY 2013

SUBMITTED BY: