

# SUBMITTAL INFORMATION

## RESETTER 6010NL-2xxN2N2-VV

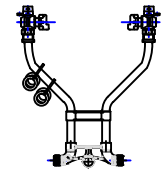

5/8" x 3/4" REDUCED PORT METER BALL VALVE BY R/P METER BALL VALVE

EXISTING - 5/8" x 3/4" METER

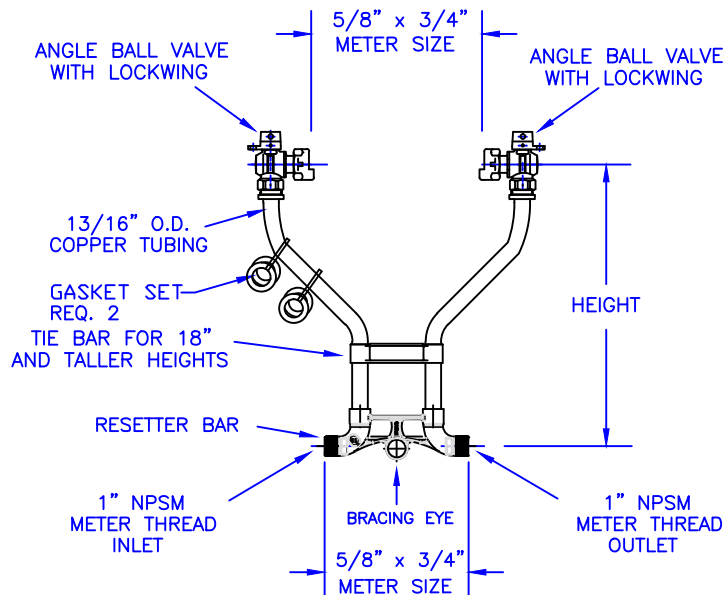

### RESETTER CATALOG NUMBERS

HEIGHT	CATALOG NUMBER	APPROX. WT. LBS.
7"	6010NL-207N2N2-VV	
9"	6010NL-209N2N2-VV	
12"	6010NL-212N2N2-VV	
15"	6010NL-215N2N2-VV	
18"	6010NL-218N2N2-VV	
21"	6010NL-221N2N2-VV	
24"	6010NL-224N2N2-VV	
27"	6010NL-227N2N2-VV	
30"	6010NL-230N2N2-VV	

#### FEATURES:

- ALL COMPONENTS CONFORM TO AWWA C800-05 (ASTM B-584, UNS NO C89833 FOR BRASS PARTS IN CONTACT WITH POTABLE WATER, AND ASTM B-62 AND B-584, UNS NO C83600 FOR ALL OTHER BRASS PARTS).
- SADDLE NUTS HOLD THE METER IN PLACE FOR TIGHTENING.
- TIE BAR IS STANDARD FOR 18" AND TALLER RESETTER HEIGHTS.
- 13/16" O.D. COPPER RISERS PROVIDE MORE FLOW CAPACITY.
- ASSEMBLED WITH LEAD-FREE SOLDER.
- BRACING EYE IS STANDARD.
- POSITIONS THE METER DIRECTLY ABOVE THE CENTERLINE OF THE SERVICE.
- FURNISHED WITH FOUR RUBBER GASKETS FOR METER NUTS AND BOTTOM BAR.
- CONSTRUCTED WITH TYPE K COPPER TUBING, ALLOY C12000 MANUFACTURED TO ASTM B88.
- ANGLE VALVE HAS PADLOCK WINGS FOR LOCKING VALVE IN CLOSED POSITION.
- METER SETTER IS SHIPPED WITH PLASTIC METER IDLER
- CONFORMS TO ANSI/NSF 372 (COMPLIANT WITH US Safe Drinking Water Act. PL 111-380)
- 300 PSI WORKING PRESSURE

Cambridge Brass considers the information in this submittal form to be correct at the time of publication. Item and option availability, including specifications, are subject to change without notice.

Cambridge Brass  
 P.O. Box 249, 140 Orion Place  
 Cambridge, Ontario  
 Canada N1R 5V1  
 Tel: (519) 621-5520  
 Fax: (519) 621-8674  
<http://www.cambridgebrass.com>

**G** CAMBRIDGE  
 BRASS

REV. B - MAY 2014

SUBMITTED BY: