

Cambridge Brass  
P.O. Box 249  
140 Orion Place  
Cambridge, Ontario  
Canada N1R 5V1  
Tel: (519) 621-5520  
Fax: (519) 621-8674  
http://www.cambridgebrass.com

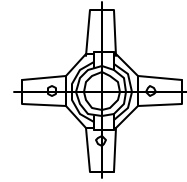

MODEL NO. 430

HANDWHEEL TYPE

IRON YOKE  
EXPANSION CONNECTION

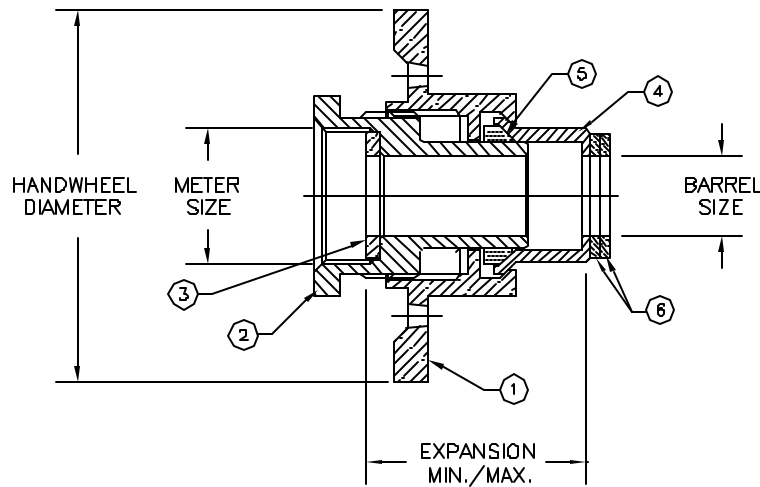

**PARTS AND MATERIAL:**

- 1. HANDWHEEL: CAST BRASS, ALLOY C84400
- 2. EXPANSION BODY: CAST BRASS, ALLOY C83600
- 3. FIBER GASKET: GARLOCK 3200
- 4. THIMBLE: COPPER, ALLOY C23000
- 5. GASKET: NITRILE RUBBER
- 6. GASKET: NITRILE RUBBER

**FEATURES:**

- MANUFACTURED IN COMPLIANCE WITH AWWA STANDARD C800-05 (ASTM B-62 AND ASTM B-584, UNS NO C83600-85-5-5-5).
- EXPANSION CONNECTION ATTACHES TO THE METER. TOGETHER, THEY ARE INSTALLED AS AN EXPANDABLE UNIT.
- ENHANCED SECURITY WHEN THE EXPANSION CONNECTION IS REMOVED ALONG WITH THE METER.
- THIMBLE NOSE PIECE DOES NOT ROTATE AFTER CONTACT WITH THE RUBBER YOKE END GASKET.

Cambridge Brass considers the information in this submittal form to be correct at the time of publication. Item and option availability, including specifications, are subject to change without notice.

METER SIZE	CATALOG NO.	BARREL SIZE	HANDWHEEL DIAMETER	EXPANSION MIN./MAX.	APPROX. WT. LBS.
5/8"	430-1	.60"	3.26"	1.44/1.75	0.7
5/8"x3/4" & 3/4"	430-3	.75"	3.50"	1.62/2.03	1.0
1"	430-4	1.00"	4.26"	1.90/2.54	1.8

Submitted by: