

Cambridge Brass
P.O. Box 249
140 Orion Place
Cambridge, Ontario
Canada N1R 5V1
Tel: (519) 621-5520
Fax: (519) 621-8674
http://www.cambridgebrass.com



MODEL NO. 423NL

METER FLANGE x SOLDER JOINT

BRASS
METER FLANGE KIT

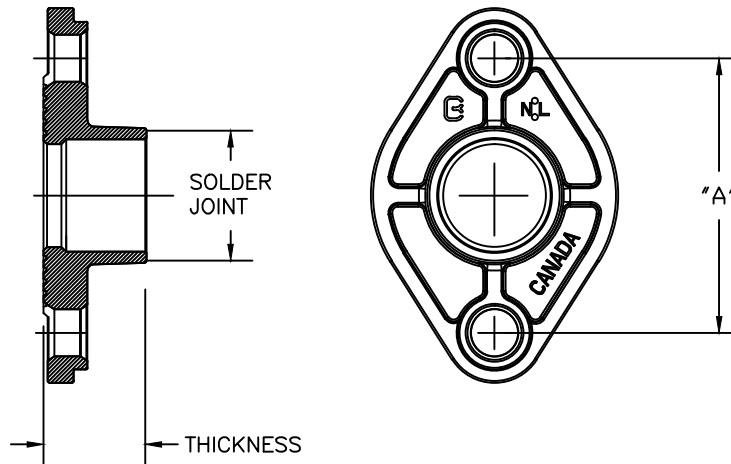

PARTS AND MATERIAL:
FLANGE: CAST BRASS, NO LEAD ALLOY C89833
BOLT: STEEL, ZINC PLATED
NUT: STEEL, ZINC PLATED
GASKET: NEOPRENE

- FEATURES:
- MANUFACTURED IN COMPLIANCE WITH AWWA STANDARD C800-05 (ASTM B-584, UNS NO C89833).
 - INCLUDES 2-FLANGES, 2-GASKETS, 4-NUTS, 4-BOLTS.
 - CONFORMS TO ANSI/NSF 61-8
 - CONFORMS TO ANSI/NSF 372 (COMPLIANT WITH US Safe Drinking Water Act. PL 111-380)
 - 300 PSI WORKING PRESSURE.

Cambridge Brass considers the information in this submittal form to be correct at the time of publication. Item and option availability, including specifications, are subject to change without notice.

METER FLANGE SIZE	CATALOG NO.	SOLDER JOINT	THICKNESS	"A"	BOLT HOLE DIAMETER	APPROX. WT. LBS.
1 1/2"	423NL-6	1 1/2"	1.50"	4"	11/16"	
2"	423NL-7	2"	1.63"	4 1/2"	13/16"	

Submitted by: