

Cambridge Brass
P.O. Box 249
140 Orion Place
Cambridge, Ontario
Canada N1R 5V1
Tel: (519) 621-5520
Fax: (519) 621-8674
http://www.cambridgebrass.com

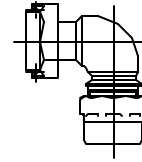

MODEL NO. 405NL

METER SWIVEL NUT x
CB COMPRESSION

ANGLE METER COUPLING

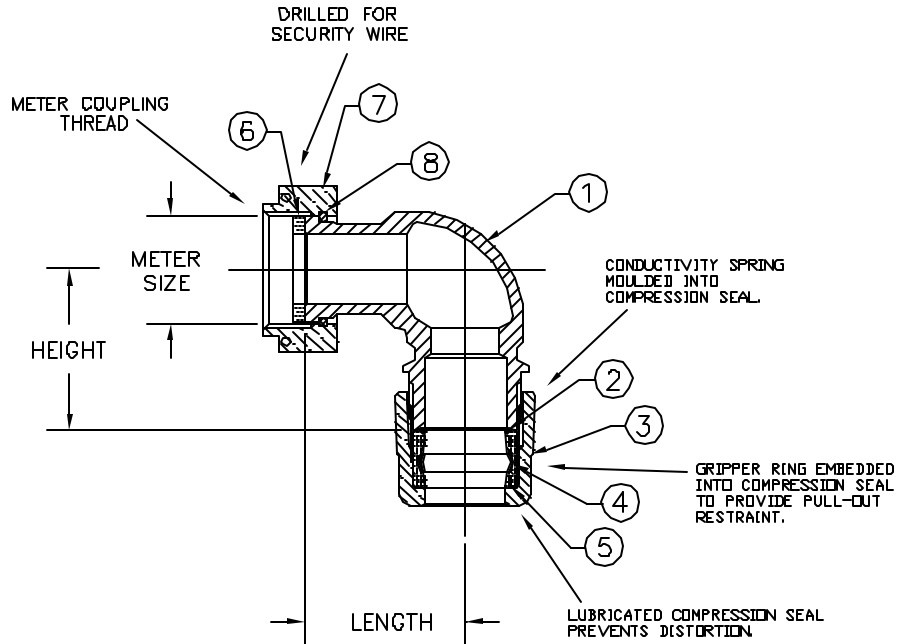

PARTS AND MATERIAL:

1. COUPLING BODY: CAST BRASS, ALLOY C89833
2. CONDUCTOR SPRING: BRASS
3. COMPRESSION NUT: CAST BRASS, ALLOY C83600
4. GRIPPER: STAINLESS STEEL, ALLOY 302
5. COMPRESSION SEAL: NITRILE RUBBER
6. SEALING WASHER: NEOPRENE RUBBER
7. METER SWIVEL NUT: CAST BRASS, ALLOY C83600
8. RETAINING RING: PHOSPHOR BRONZE WIRE

FEATURES:

- MANUFACTURED IN COMPLIANCE WITH AWWA STANDARD C800-05 (ASTM B-584, UNS NO C89833).
- CONFORMS TO AWWA C700 FOR METER THREADS.
- BODY PROVIDES WRENCH FLATES FOR PROPER INSTALLATION.

Cambridge Brass considers the information in this submittal form to be correct at the time of publication. Item and option availability, including specifications, are subject to change without notice.

CATALOG NO.	METER SIZE	METER THREAD	CB COMPRESSION	HEIGHT	LENGTH	APPROX. WT. LBS.
405NL-T3H3	5/8"x3/4" & 3/4"	1" NPSM	3/4"	1.79"	1.79"	1.1

Submitted by: