

Cambridge Brass
P.O. Box 249
140 Orion Place
Cambridge, Ontario
Canada N1R 5V1
Tel: (519) 621-5520
Fax: (519) 621-8674
http://www.cambridgebrass.com

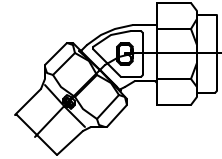

MODEL NO. 306NL

FEMALE COPPER FLARE x
COPPER FLARE

SWIVEL EIGHTH BEND

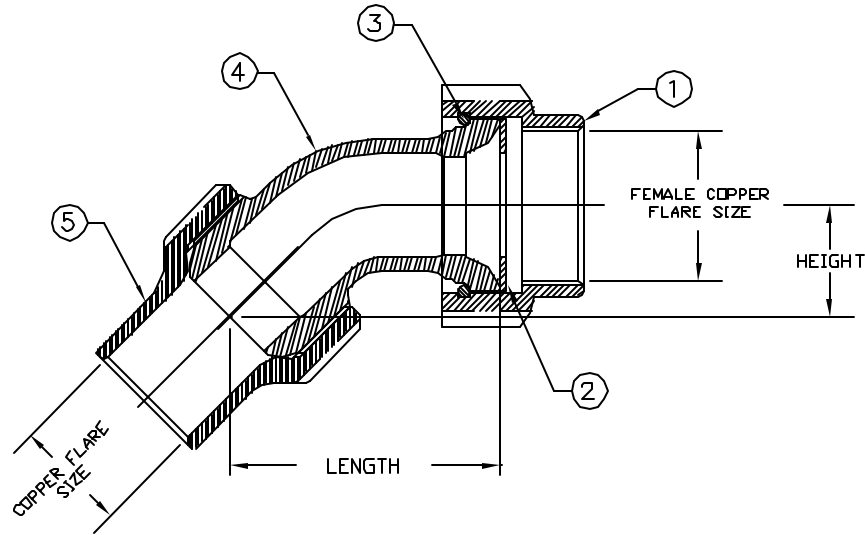

- PARTS AND MATERIAL:
1. SWIVEL NUT: CAST BRASS, ALLOY C84400
 2. SEALING WASHER: COPPER
 3. RETAINING RING: PHOSPHOR BRONZE
 4. BODY: CAST BRASS, ALLOY C89833
 5. NUT: CAST BRASS, ALLOY C83600

- FEATURES:
- MANUFACTURED IN COMPLIANCE WITH AWWA STANDARD C800-05 (ASTM B-584, UNS NO C89833).
 - CSA CLASSIFIED TO ANSI/NSF STANDARD 61-8.
 - SWIVEL NUT INLET ALLOWS PROPER OUTLET POSITIONING WITHOUT COMPROMISING INTALLATION TORQUE.
 - SEALING WASHER IS CAPTURED BY SWIVEL NUT AND ARE NOT REPLACEABLE.
 - BODY DESIGN PROVIDES LARGE, RUGGED WRENCH FLATS FOR PROPER INSTALLATION.

Cambridge Brass considers the information in this submittal form to be correct at the time of publication. Item and option availability, including specifications, are subject to change without notice.

CATALOG NO.	FEMALE COPPER FLARE	COPPER FLARE	LENGTH	HEIGHT	APPROX. WT. LBS.
306NL-P4C4	1"	1"	2.75"	1.12"	2.0
306NL-P6C6	1 1/2"	1 1/2"	3.88"	1.75"	6.1
306NL-P7C7	2"	2"	4.38"	2.00"	9.3

Submitted by: