

Cambridge Brass
P.O. Box 249
140 Orion Place
Cambridge, Ontario
Canada N1R 5V1
Tel: (519) 621-5520
Fax: (519) 621-8674
http://www.cambridgebrass.com

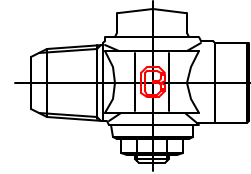

MODEL NO. 302NL

AWWA (CC) x FEMALE IRON PIPE

CORPORATION MAIN STOP
PLUG STYLE

AWWA/CC TAPER THREAD INLET x FEMALE IRON PIPE THREAD OUTLET

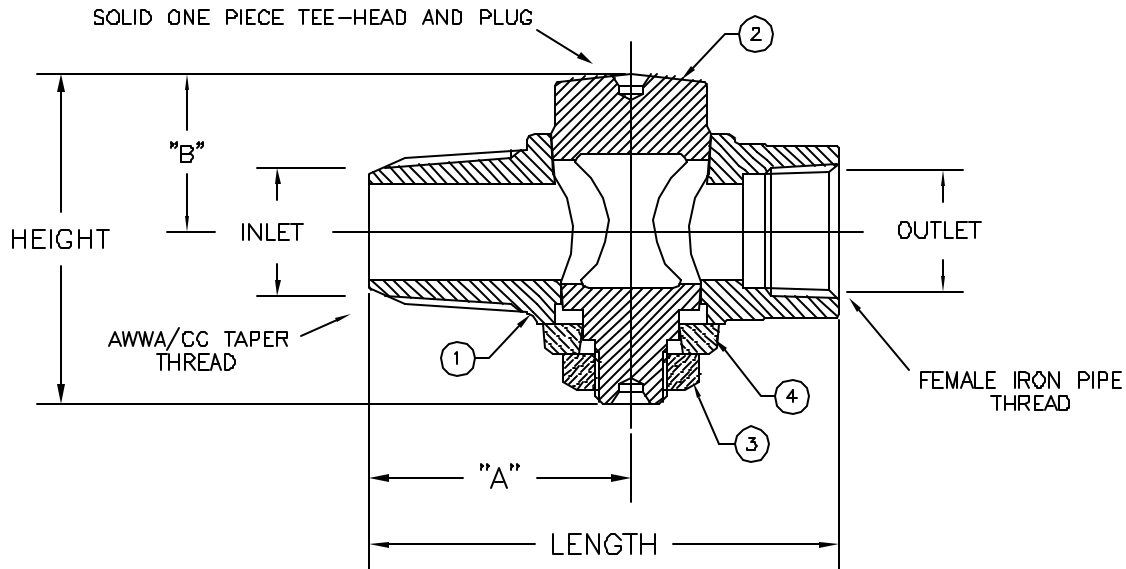

- PARTS AND MATERIAL:
1. VALVE BODY: CAST BRASS, ALLOY C89833
 2. TAPERED PLUG: CAST BRASS, ALLOY C89833
 3. STOP NUT: CAST BRASS, ALLOY C83600
 4. WASHER: CAST BRASS, ALLOY C83600

FEATURES:

- ALL COMPONENTS CONFORM TO AWWA 800-05 (ASTM B-584, UNS NO C89833 FOR ALL BRASS PARTS IN CONTACT WITH POTABLE WATER, AND ASTM B-62 AND ASTM B-584, UNS NO C83600 FOR ALL OTHER BRASS PARTS).
- CSA CLASSIFIED TO ANSI/NSF STANDARD 61-8.
- BODY PROVIDES LARGE, RUGGED WRENCH FLATS FOR PROPER INSTALLATION.
- 100 PSI WORKING PRESSURE.
- FULL 360 DEGREE ROTATION.

Cambridge Brass considers the information in this submittal form to be correct at the time of publication. Item and option availability, including specifications, are subject to change without notice.

VALVE SIZE	CATALOG NO.	INLET AWWA (CC)	OUTLET F.I.P.	HEIGHT	LENGTH	"A"	"B"	APPROX. WT. LBS.
3/4"	302NL-A3F3	3/4"	3/4"	2.54"	3.69"	2.06"	1.21"	1.4
1"	302NL-A4F4	1"	1"	2.75"	4.35"	2.41"	1.30"	2.5

Submitted by: