

Cambridge Brass
P.O. Box 249
140 Orion Place
Cambridge, Ontario
Canada N1R 5V1
Tel: (519) 621-5520
Fax: (519) 621-8674
http://www.cambridgebrass.com

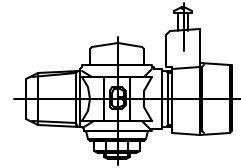

MODEL NO. 302

AWWA (CC) x CB COMPRESSION ELECTRICAL

CORPORATION MAIN STOP
PLUG STYLE

AWWA/CC TAPER THREAD INLET x CB COMPRESSION ELECTRICAL
FOR COPPER OR PLASTIC TUBING (CTS) OUTLET

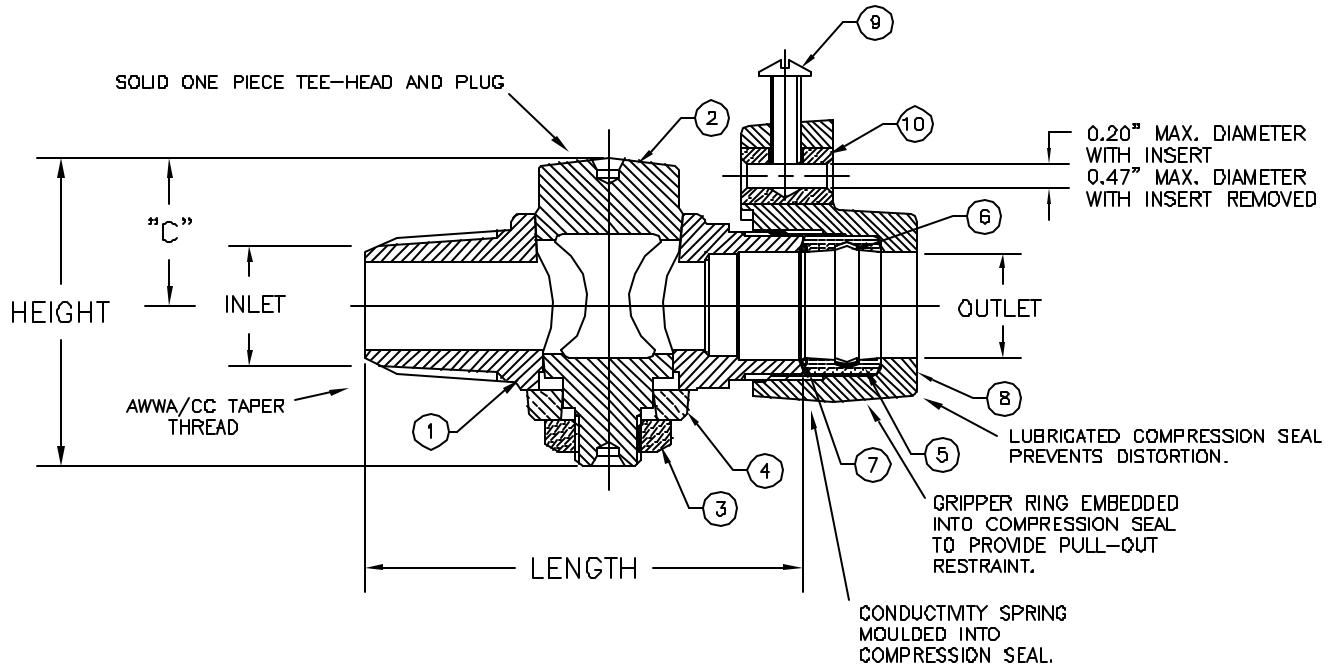

PARTS AND MATERIAL:

1. VALVE BODY: CAST BRASS, ALLOY C83600
2. TAPERED PLUG: CAST BRASS, ALLOY C83600
3. STOP NUT: COPPER, ALLOY C36000
4. WASHER: CAST BRASS, ALLOY C83600
5. COMPRESSION SEAL: NITRILE RUBBER
6. GRIPPER: STAINLESS STEEL, TYPE 302
7. CONDUCTOR SPRING: BRASS
8. ELECTRICAL TAILNUT: CAST BRASS, ALLOY C83600
9. SCREW: SILICON BRONZE
10. INSERT: COPPER, ALLOY C14500

FEATURES:

- MANUFACTURED IN COMPLIANCE WITH AWWA STANDARD C800-05 (ASTM B-62 AND ASTM B-584, UNS NO C83600-85-5-5-5).
- CSA CLASSIFIED TO ANSI/NSF STANDARD 61-B.
- BODY PROVIDES LARGE, RUGGED WRENCH FLATES FOR PROPER INSTALLATION.
- 100 PSI WORKING PRESSURE.

Cambridge Brass considers the information in this submittal form to be correct at the time of publication. Item and option availability, including specifications, are subject to change without notice.

VALVE SIZE	CATALOG NO.	INLET AWWA (CC)	OUTLET CB ELECT.	"C"	HEIGHT	LENGTH	APPROX. WT. LBS.
3/4"	302-A3HE3	3/4"	3/4"	1.21"	2.60"	3.69"	2.0
1"	302-A4HE4	1"	1"	1.30"	2.75"	4.22"	3.0

Submitted by: