

Cambridge Brass
P.O. Box 249
140 Orion Place
Cambridge, Ontario
Canada N1R 5V1
Tel: (519) 621-5520
Fax: (519) 621-8674
http://www.cambridgebrass.com

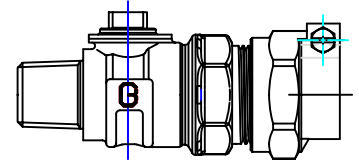

MODEL NO. 301

MIP x PVC

CORPORATION MAIN STOP
BALL STYLE

MIP TAPER THREAD INLET BY PVC OUTLET

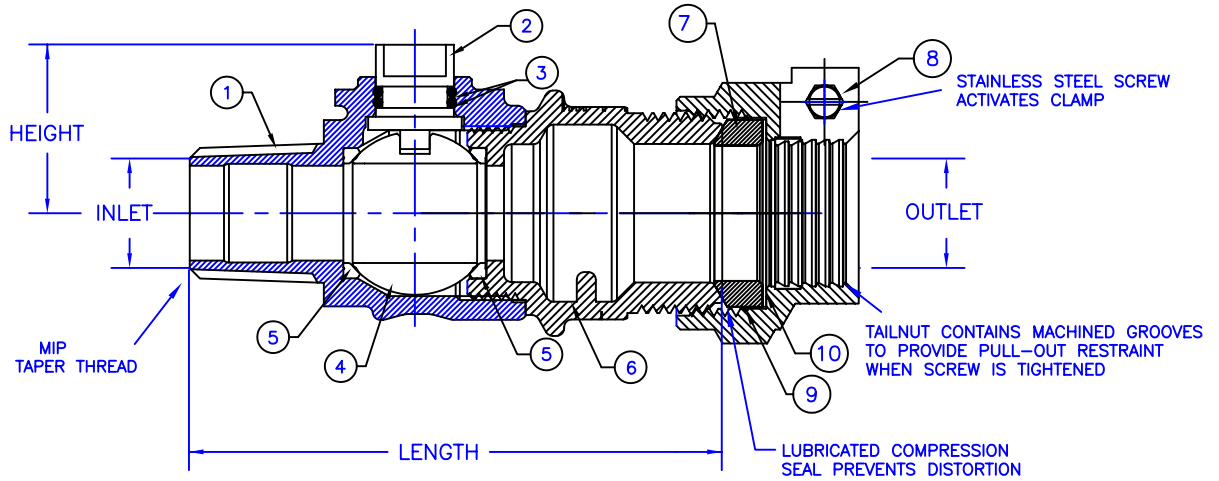

PARTS AND MATERIAL:

1. VALVE BODY: CAST BRASS, ALLOY C83600
2. STEM: STAINLESS STEEL, TYPE 303
3. O-RING: NITRILE RUBBER
4. BALL: CAST BRASS, ALLOY C89833
5. SEATS: TEFLON
6. ENDBODY: CAST BRASS, ALLOY C83600
7. COMPRESSION SEAL: NITRILE RUBBER
8. SCREW: STAINLESS STEEL, ALLOY 304
9. CAMPAK NUT: CAST BRASS, ALLOY C83600
10. ANTI-FRICTION RING: HDPE

FEATURES:

- ALL COMPONENTS CONFORM TO AWWA C800-05
ASTM B-62 AND B-584, UNS NO C83600 FOR ALL OTHER BRASS PARTS
- CSA CLASSIFIED TO ANSI/NSF STANDARD 61-8.
- BLOWOUT PROOF DESIGN.
- 300 PSI WORKING PRESSURE.
- BODY PROVIDES LARGE, RUGGED FLATS FOR PROPER INSTALLATION.
- FULL 360 DEGREE ROTATION.

Cambridge Brass considers the information in this submittal form to be correct at the time of publication. Item and option availability, including specifications, are subject to change without notice.

VALVE SIZE	CATALOG NO.	INLET M.I.P.	OUTLET CAMPAK	LENGTH	HEIGHT	APPROX. WT. LBS.	CLASSIFIED NSF 61-8
1 1/4"	301-M5PJ5	1 1/4"	1 1/4"	5.65"	1.75"	4.34	

Submitted by: