

Cambridge Brass
P.O. Box 249
140 Orion Place
Cambridge, Ontario
Canada N1R 5V1
Tel: (519) 821-8520
Fax: (519) 621-8674
http://www.cambridgebrass.com

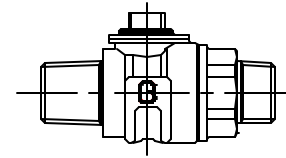

MODEL NO. 301

MALE IRON PIPE x MALE IRON PIPE

CORPORATION MAIN STOP
BALL STYLE

MALE IRON PIPE THREAD INLET BY MALE IRON PIPE THREAD OUTLET

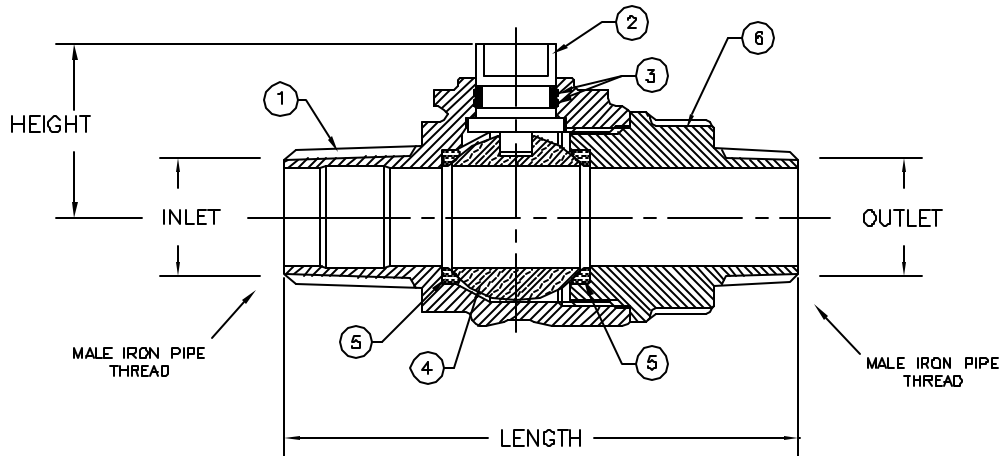

PARTS AND MATERIAL:

- 1. VALVE BODY: CAST BRASS, ALLOY C83600
- 2. STEM: STAINLESS STEEL, TYPE 303
- 3. O-RING: NITRILE RUBBER
- 4. BALL: CAST BRASS, ALLOY C89833
- 5. SEATS: TEFLON
- 6. ENDBODY: CAST BRASS, ALLOY C83600

FEATURES:

- MANUFACTURED IN COMPLIANCE WITH AWWA STANDARD C800-05 (ASTM B-62 AND ASTM B-584, UNS NO C83600-85-5-5-5).
- <X> CLASSIFIED TO ANSI/NSF STANDARD 61-8.
- BLOWOUT PROOF DESIGN.
- 300 PSI WORKING PRESSURE.
- BODY PROVIDES LARGE, RUGGED FLATS FOR PROPER INSTALLATION.
- FULL 360 DEGREE ROTATION.

Cambridge Brass considers the information in this submittal form to be correct at the time of publication. Item and option availability, including specifications, are subject to change without notice.

| VALVE SIZE | CATALOG NO. | INLET M.I.P. | OUTLET M.I.P. | LENGTH | HEIGHT | APPROX. WT. LBS. | CLASSIFIED NSF 61-8 |
|------------|-------------|--------------|---------------|--------|--------|------------------|---------------------|
| 3/4" | 301-M3M3 | 3/4" | 3/4" | 3.96" | 1.33" | 1.4 | <X> |
| 1" | 301-M4M4 | 1" | 1" | 4.71" | 1.51" | 2.2 | <X> |
| 1 1/2" | 301-M6M6 | 1 1/2" | 1 1/2" | 6.40" | 2.17" | 6.3 | <X> |
| 1 1/2" | 301-M6M7 | 1 1/2" | 2" | 6.40" | 2.17" | 7.2 | |
| 2" | 301-M7M7 | 2" | 2" | 6.85" | 2.47" | 8.8 | |

Submitted by: