

Cambridge Brass
P.O. Box 249
140 Orion Place
Cambridge, Ontario
Canada N1R 5V1
Tel: (519) 621-5520
Fax: (519) 621-8674
http://www.cambridgebrass.com

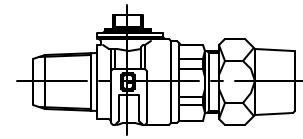

MODEL NO. 301

AWWA (CC) x GRIP JOINT

CORPORATION MAIN STOP
BALL STYLE

AWWA/CC TAPER THREAD INLET BY GRIP JOINT FOR COPPER OR PLASTIC TUBING (CTS) OUTLET

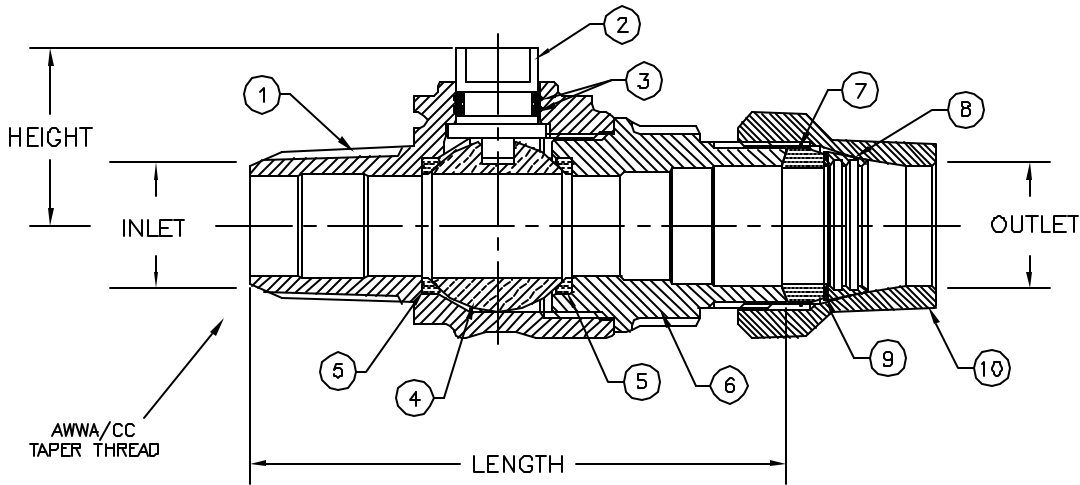

PARTS AND MATERIAL:

1. VALVE BODY: CAST BRASS, ALLOY C83600
2. STEM: STAINLESS STEEL, TYPE 303
3. O-RING: NITRILE RUBBER
4. BALL: COPPER ALLOY, NO LEAD
5. SEATS: TEFLON
6. ENDBODY: CAST BRASS, ALLOY C83600
7. GASKET: NITRILE RUBBER
8. GRIPPER: BRASS, ALLOY C26000
9. WASHER: POLYETHYLENE
10. GRIP JOINT NUT: CAST BRASS, ALLOY C83600

FEATURES:

- MANUFACTURED IN COMPLIANCE WITH AWWA STANDARD C800-05 (ASTM B-82 AND ASTM B-584, UNS NO C83600-85-5-5-5).
- CSA CLASSIFIED TO ANSI/NSF STANDARD 61-8.
- BLOWOUT PROOF DESIGN.
- 300 PSI WORKING PRESSURE.
- BODY PROVIDES LARGE, RUGGED FLATS FOR PROPER INSTALLATION.
- FULL 360 DEGREE ROTATION.

Cambridge Brass considers the information in this submittal form to be correct at the time of publication. Item and option availability, including specifications, are subject to change without notice.

VALVE SIZE	CATALOG NO.	INLET AWWA (CC)	OUTLET GRIP JOINT	LENGTH	HEIGHT	APPROX. WT. LBS.
3/4"	301-A3GJ3	3/4"	3/4"	4.05"	1.33"	1.7
1"	301-A4GJ4	1"	1"	4.59"	1.51"	2.9

Submitted by: