

Cambridge Brass
P.O. Box 249
140 Orion Place
Cambridge, Ontario
Canada N1R 5V1
Tel: (519) 621-5520
Fax: (519) 621-8674
http://www.cambridgebrass.com

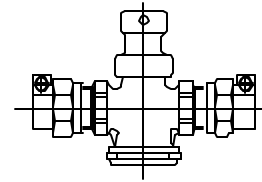

MODEL NO. 290

CAMPAK x CAMPAK

CURB STOP
INVERTED KEY PLUG STYLE

FOR COPPER OR PLASTIC TUBING (CTS)

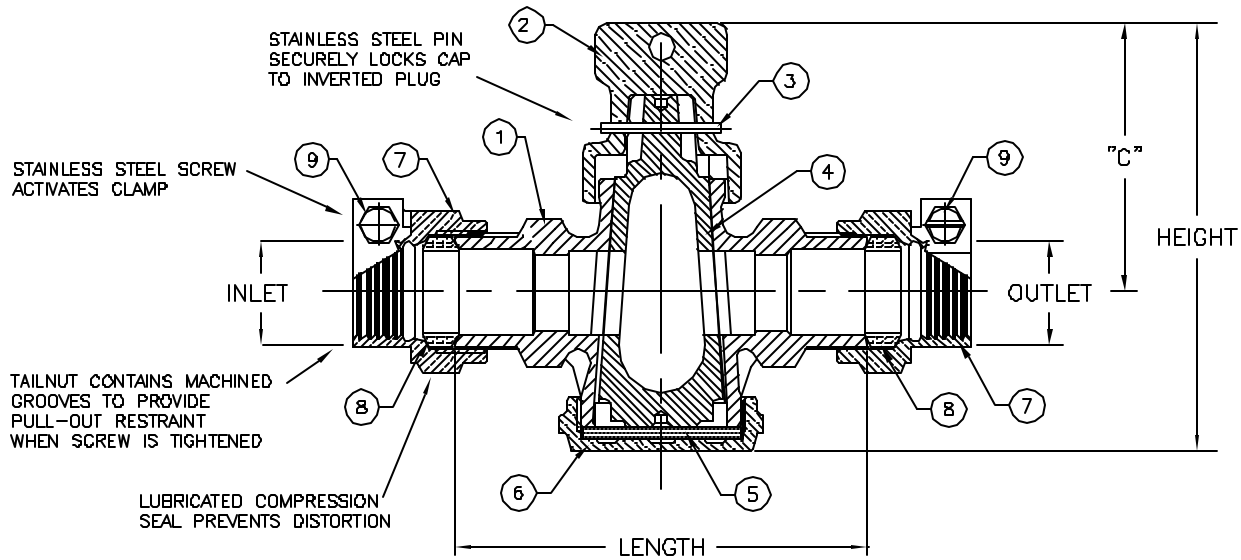

PARTS AND MATERIAL:

1. VALVE BODY: CAST BRASS, ALLOY C83600
2. TOP CAP: CAST BRASS, ALLOY C84400
3. SPIRAL PIN: STAINLESS STEEL, TYPE 302
4. PLUG: CAST BRASS, ALLOY C83600
5. BOTTOM WASHER: POLYETHYLENE
6. BOTTOM CAP: CAST BRASS, ALLOY C83600
7. CAMPAK TAILNUT: CAST BRASS, ALLOY C83600
8. COMPRESSION SEAL: NITRILE RUBBER
9. SCREW: STAINLESS STEEL, ALLOY 304

FEATURES:

- MANUFACTURED IN COMPLIANCE WITH AWWA STANDARD C800-05 (ASTM B-62 AND ASTM B-584, UNS NO C83600-85-5-5-5).
- CSA CLASSIFIED TO ANSI/NSF STANDARD 61-8.
- HOLE FOR ATTACHING CURB BOX ROD IS PROVIDED IN CAP.
- ENCAPSULATED LUGS UNDER CAP PROVIDE 90 DEGREE OPEN TO CLOSE OPERATION.
- 100 PSI WORKING PRESSURE.

Cambridge Brass considers the information in this submittal form to be correct at the time of publication. Item and option availability, including specifications, are subject to change without notice.

VALVE SIZE	CATALOG NO.	INLET CAMPAK	OUTLET CAMPAK	"C"	HEIGHT	LENGTH	APPROX. WT. LBS.
3/4"	290-B3B3	3/4"	3/4"	2.82"	4.48"	4.31"	

Submitted by: