

Cambridge Brass
P.O. Box 249
140 Orion Place
Cambridge, Ontario
Canada N1R 5V1
Tel: (519) 621-5520
Fax: (519) 621-8674
http://www.cambridgebrass.com

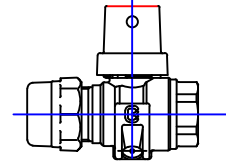

MODEL NO. 253NL

CB COMPRESSION x FEMALE IRON PIPE

CURB STOP – BALL STYLE
DRAINING
OPEN RIGHT

FOR COPPER OR PLASTIC TUBING (CTS) x THREADED PIPE

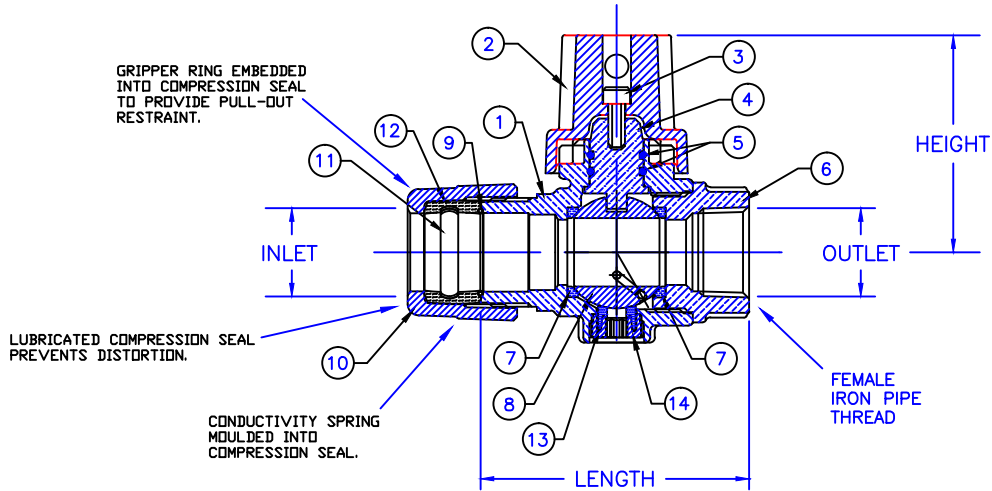

- PARTS AND MATERIAL:**
1. VALVE BODY: CAST BRASS, NO LEAD ALLOY C89833
 2. CAP: CAST BRASS, ALLOY C83600
 3. CAP SCREW: STAINLESS STEEL, TYPE 304
 4. STEM: STAINLESS STEEL, TYPE 303
 5. O-RING: NITRILE RUBBER
 6. ENDBODY: CAST BRASS, NO LEAD ALLOY C83600
 7. SEATS: TEFLON
 8. BALL: CAST BRASS, NO LEAD ALLOY C89833
 9. CONDUCTOR SPRING: BRASS
 10. TAILNUT: CAST BRASS, ALLOY C83600
 11. GRIPPER: STAINLESS STEEL, TYPE 302
 12. COMPRESSION SEAL: EPDM
 13. DRAIN SEAL: NITRILE RUBBER
 14. DRAIN PLUG: COPPER, ALLOY C36000

FEATURES:

- CONFORMS TO AWWA C800 (ASTM B584 UNS C89833 FOR BRASS PARTS IN CONTACT WITH POTABLE WATER)
- CONFORMS TO ANSI/NSF 61-8
- CONFORMS TO ANSI/NSF 372 (COMPLIANT WITH US Safe Drinking Water Act. PL 111-380)
- BODY AND NUTS PROVIDE WRENCH FLATS FOR INSTALLATION
- ENCAPSULATED LUGS UNDER CAP PROVIDE 90 DEGREE OPEN TO CLOSE OPERATION
- 300PSI WORKING PRESSURE
- BLOWOUT PROOF STEM DESIGN
- VALVES ARE DIRECTIONAL (FLOW DIRECTION ARROWS PROVIDED ON BODY)

ORDERING INFORMATION:
HANDLE = ADD "H" TO END OF CATALOG NO.

Cambridge Brass considers the information in this submittal form to be correct at the time of publication. Item and option availability, including specifications, are subject to change without notice.

VALVE SIZE	CATALOG NO.	INLET CB COMP.	OUTLET F.I.P.	LENGTH	HEIGHT	APPROX. WT. LBS.
3/4"	253NL-H3F3	3/4"	3/4"	3.10"	2.50"	2.0
1"	253NL-H4F4	1"	1"	3.67"	2.68"	3.0
1 1/2"	253NL-H6F6	1 1/2"	1 1/2"	5.59"	3.31"	7.8
2"	253NL-H7F7	2"	2"	5.86"	3.61"	10.7

Submitted by: