

Cambridge Brass
P.O. Box 249
140 Orion Place
Cambridge, Ontario
Canada N1R 5V1
Tel: (519) 621-5520
Fax: (519) 621-8674
http://www.cambridgebrass.com

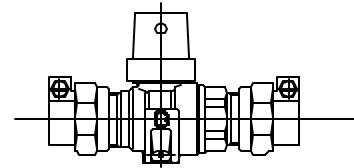

MODEL NO. 253

CAMPAK x CAMPAK

CURB STOP – BALL STYLE
DRAINING
OPEN RIGHT

FOR COPPER OR PLASTIC TUBING (CTS)

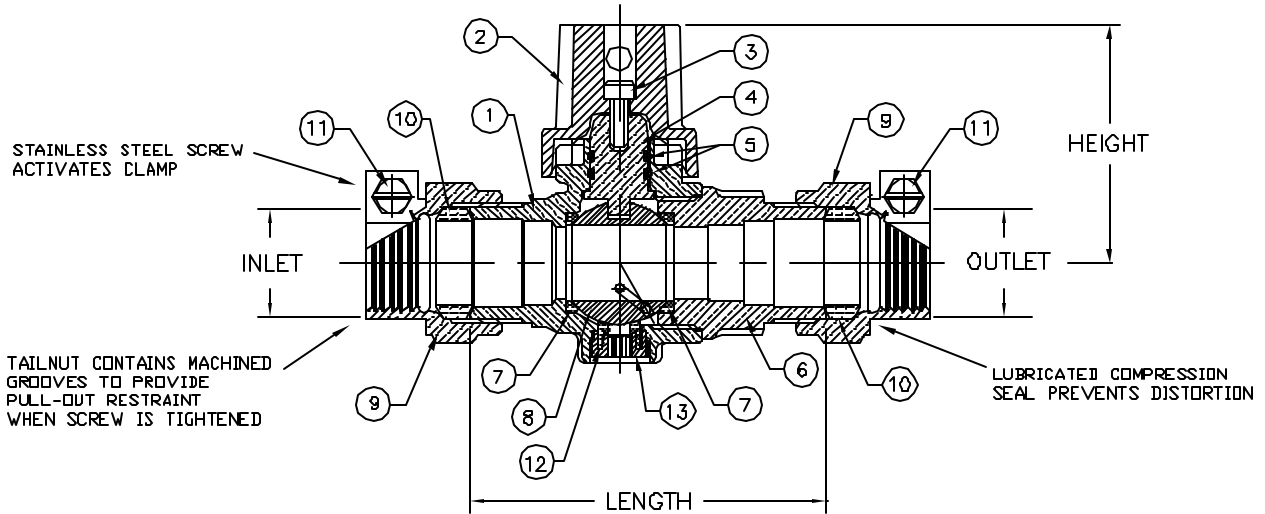

PARTS AND MATERIAL:

1. VALVE BODY: CAST BRASS, ALLOY C83600
2. CAP: CAST BRASS, ALLOY C83600
3. CAP SCREW: STAINLESS STEEL, TYPE 304
4. STEM: STAINLESS STEEL, TYPE 303
5. O-RING: NITRILE RUBBER
6. ENDBODY: CAST BRASS, ALLOY C83600
7. SEATS: TEFLON
8. BALL: COPPER ALLOY, NO LEAD
9. TAILNUT: CAST BRASS, ALLOY C83600
10. COMPRESSION SEAL: NITRILE RUBBER
11. SCREW: STAINLESS STEEL, ALLOY 304
12. DRAIN SEAL: NITRILE RUBBER
13. DRAIN PLUG: COPPER, ALLOY C36000

FEATURES:

- MANUFACTURED IN COMPLIANCE WITH AWWA STANDARD C800-05 (ASTM B62 AND ASTM B-5B4, UNS NO C83600-B5-5-5-5).
- <X> CSA CLASSIFIED TO ANSI/NSF STANDARD 61-8.
- ROTATION STOPS RESISTS 200 FT-LB TORQUE.
- ENCAPSULATED LUGS UNDER CAP PROVIDE 90 DEGREE OPEN TO CLOSE OPERATION.
- HOLE FOR ATTACHING CURB BOX ROD OR HANDLE IS PROVIDED IN CAP.
- BLOWOUT PROOF DESIGN.
- 300 PSI WORKING PRESSURE.
- VALVES ARE DIRECTIONAL (FLOW DIRECTION ARROWS PROVIDED ON BODY).

ORDERING INFORMATION:

HANDLE = ADD "H" TO END OF CATALOG NO.

Cambridge Brass considers the information in this submittal form to be correct at the time of publication. Item and option availability, including specifications, are subject to change without notice.

VALVE SIZE	CATALOG NO.	INLET CAMPAK	OUTLET CAMPAK	LENGTH	HEIGHT	APPROX. WT. LBS.	CLASSIFIED NSF 61-8
3/4"	253-B3B3	3/4"	3/4"	3.75"	2.50"		<X>
1"	253-B4B4	1"	1"	4.42"	2.68"		<X>
1 1/2"	253-B6B6	1 1/2"	1 1/2"	6.56"	3.31"		<X>
2"	253-B7B7	2"	2"	6.83"	3.61"		

Submitted by: