

Cambridge Brass
P.O. Box 249
140 Orion Place
Cambridge, Ontario
Canada N1R 5V1
Tel: (519) 621-5520
Fax: (519) 621-8674
http://www.cambridgebrass.com

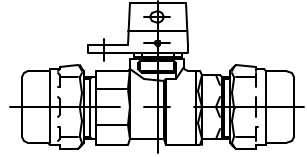

MODEL NO. 224

CB COMPRESSION x CB COMPRESSION

CURB STOP – BALL STYLE
REDUCED PORT WITH LOCKWING

FOR COPPER OR PLASTIC TUBING (CTS)

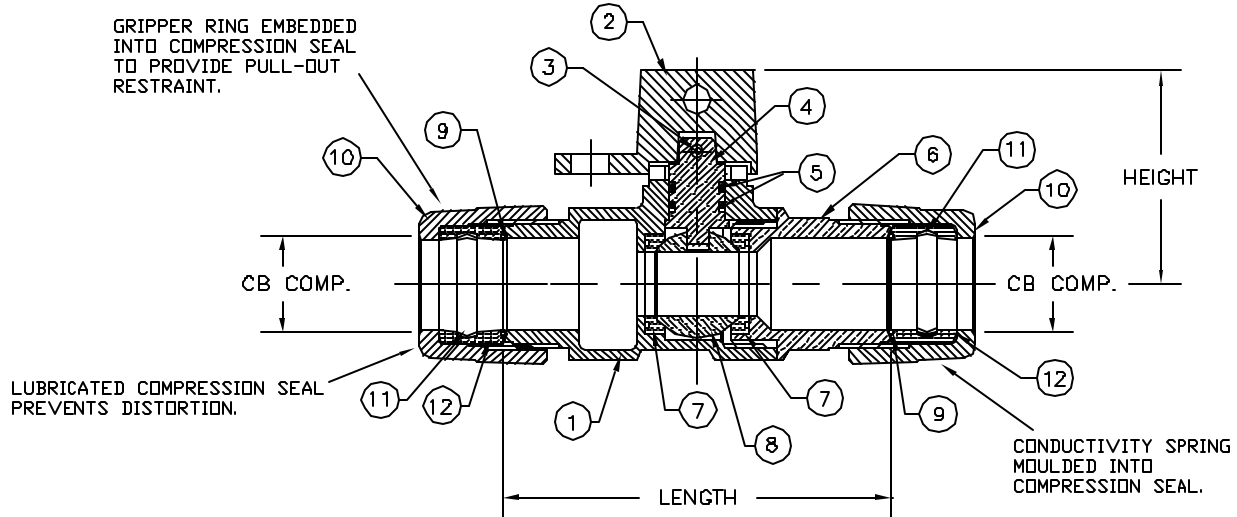

- PARTS AND MATERIAL:**
1. VALVE BODY: CAST BRASS, ALLOY C83600
 2. LOCKING CAP: CAST BRASS, ALLOY C84400
 3. CAP PIN: STAINLESS STEEL, TYPE 420
 4. STEM: COPPER, ALLOY C83600
 5. O-RING: NITRILE RUBBER
 6. ENDBODY: CAST BRASS, ALLOY C83600
 7. SEATS: NITRILE RUBBER
 8. BALL: COPPER, ALLOY C83600, TEFLON COATED
 9. CONDUCTOR SPRING: BRASS
 10. TAILNUT: CAST BRASS, ALLOY C83600
 11. GRIPPER: STAINLESS STEEL, TYPE 302
 12. COMPRESSION SEAL: NITRILE RUBBER

- FEATURES:**
- MANUFACTURED IN COMPLIANCE WITH AWWA STANDARD C800-05 (ASTM B-62 AND ASTM B-584, UNS NO C83600-85-5-5-5).
 - CSA CLASSIFIED TO ANSI/NSF STANDARD 61-8.
 - FLOW CAN BE IN EITHER DIRECTION.
 - BLOWOUT PROOF DESIGN.
 - 200 PSI WORKING PRESSURE.
 - HOLE FOR ATTACHING HANDLE IS PROVIDED IN CAP.
 - PADLOCK WING FOR LOCKING VALVE IN CLOSED POSITION.

ORDERING INFORMATION:
FULL 360 ROTATION - ADD "R" TO END OF CATALOG NO.
HANDLE - ADD "H" TO END OF CATALOG NO.

Cambridge Brass considers the information in this submittal form to be correct at the time of publication. Item and option availability, including specifications, are subject to change without notice.

| VALVE SIZE | CATALOG NO. | CB COMP. | CB COMP. | LENGTH | HEIGHT | APPROX. WT. LBS. |
|------------|-------------|----------|----------|--------|--------|------------------|
| 5/8" | 224-H3H3 | 3/4" | 3/4" | 3.83" | 2.12" | |

Submitted by: