

Cambridge Brass  
 P.O. Box 249  
 140 Orion Place  
 Cambridge, Ontario  
 Canada N1R 5V1  
 Tel: (519) 621-5520  
 Fax: (519) 621-8674  
 http://www.cambridgebrass.com

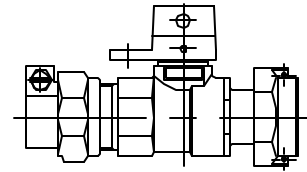

MODEL NO. 224

CAMPAK x METER SWIVEL NUT

CURB STOP – BALL STYLE  
 REDUCED PORT WITH LOCKWING

FOR COPPER OR PLASTIC TUBING (CTS) x METER SPUD

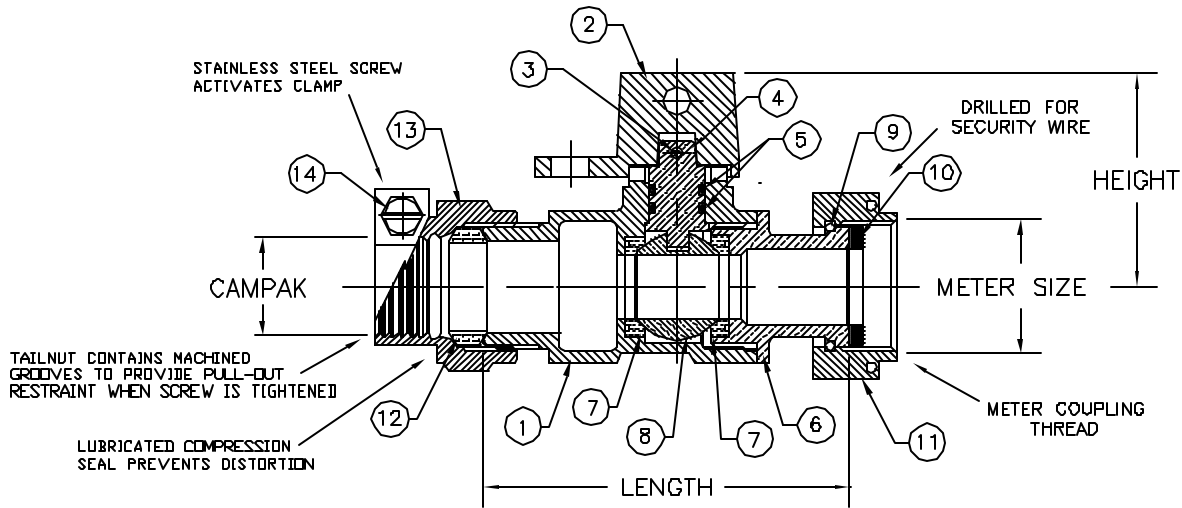

**PARTS AND MATERIAL:**

1. VALVE BODY: CAST BRASS, ALLOY C83600
2. LOCKING CAP: CAST BRASS, ALLOY C84400
3. CAP PIN: STAINLESS STEEL, TYPE 420
4. STEM: COPPER, ALLOY C83600
5. O-RING: NITRILE RUBBER
6. ENDBODY: CAST BRASS, ALLOY C83600
7. SEATS: NITRILE RUBBER
8. BALL: COPPER, ALLOY C83600, TEFLON COATED
9. RETAINER RING: PHOSFOR BRONZE WIRE
10. SEALING WASHER: NEOPRENE RUBBER
11. METER SWIVEL NUT: CAST BRASS, ALLOY C84400
12. COMPRESSION SEAL: NITRILE RUBBER
13. CAMPAK NUT: CAST BRASS, ALLOY C83600
14. SCREW: STAINLESS STEEL, ALLOY 304

**FEATURES:**

- MANUFACTURED IN COMPLIANCE WITH AWWA STANDARD C800-05 (ASTM B-62 AND ASTM B-584, UNS NO C83600-85-5-5-5).
- CSA CLASSIFIED TO ANSI/NSF STANDARD 61-8.
- FLOW CAN BE IN EITHER DIRECTION.
- BLOWOUT PROOF DESIGN.
- 200 PSI WORKING PRESSURE.
- HOLE FOR ATTACHING HANDLE IS PROVIDED IN CAP.
- PADLOCK WING FOR LOCKING VALVE IN CLOSED POSITION.
- METER THREADS CONFORM TO AWWA C700.

**ORDERING INFORMATION:**

FULL 360 ROTATION = ADD "R" TO END OF CATALOG NO.  
 HANDLE = ADD "H" TO END OF CATALOG NO.

Cambridge Brass considers the information in this submittal form to be correct at the time of publication. Item and option availability, including specifications, are subject to change without notice.

VALVE SIZE	CATALOG NO.	CAMPAK	METER SIZE	LENGTH	HEIGHT	APPROX. WT. LBS.
5/8"	224-B3T3	3/4"	5/8"x3/4" & 3/4"	3.62"	2.12"	

Submitted by: