

Cambridge Brass
P.O. Box 249
140 Orion Place
Cambridge, Ontario
Canada N1R 5V1
Tel: (519) 621-5520
Fax: (519) 621-8674
http://www.cambridgebrass.com

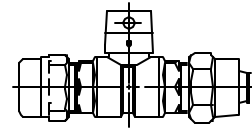

MODEL NO. 204

CB COMPRESSION x P.E.P.

CURB STOP - BALL STYLE
REDUCED PORT

FOR COPPER OR PLASTIC TUBING (CTS) x POLYETHYLENE PLASTIC PIPE, SIDR-7, IPS SIZE

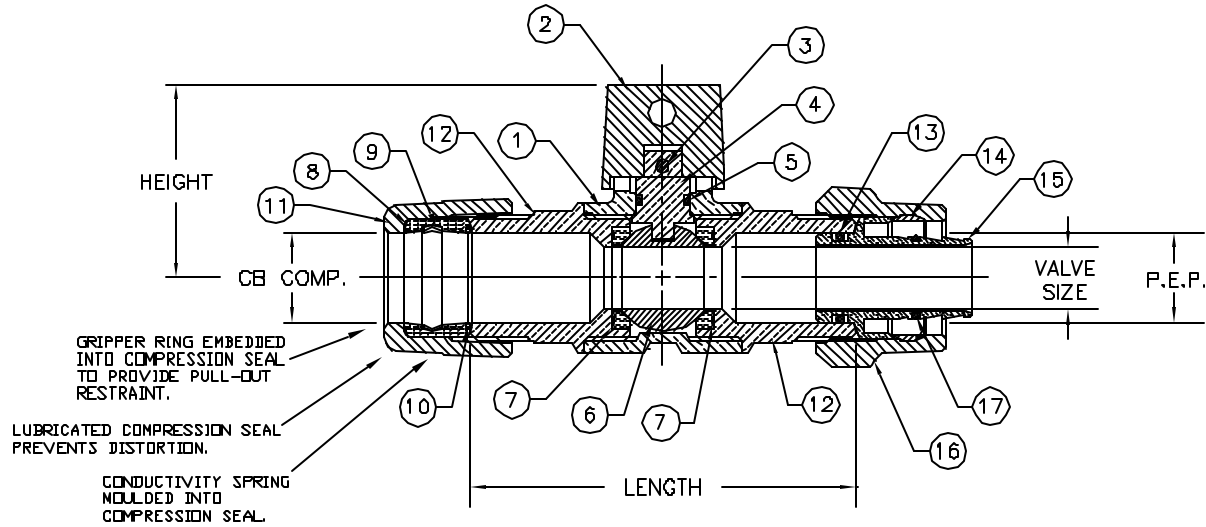

PARTS AND MATERIAL:

1. VALVE BODY: CAST BRASS, ALLOY C83600
2. CAP: CAST BRASS, ALLOY C84400
3. SPRING PIN: STAINLESS STEEL, TYPE 402
4. STEM: COPPER, ALLOY C83600
5. O-RING: NITRILE RUBBER
6. BALL: COPPER, ALLOY C83600, TEFLON COATED
7. SEATS: NITRILE RUBBER
8. GRIPPER: STAINLESS STEEL, TYPE 302
9. COMPRESSION SEAL: NITRILE RUBBER
10. CONDUCTOR SPRING: BRASS
11. CB COMP. NUT: CAST BRASS, ALLOY C83600
12. TAILPIECE: CAST BRASS, ALLOY C83600
13. O-RING: NITRILE RUBBER
14. GRIPPER: BRASS, ALLOY C26000
15. INSERT: COPPER, ALLOY C23000
16. P.E.P. NUT: CAST BRASS, ALLOY C83600
17. O-RING: NITRILE RUBBER

FEATURES:

- MANUFACTURED IN COMPLIANCE WITH AWWA STANDARD C800.
- BLOWOUT PROOF DESIGN.
- 200 PSI WORKING PRESSURE.
- FLOW CAN BE IN EITHER DIRECTION.

ORDERING INFORMATION:

FULL 360 ROTATION = ADD "R" TO END OF CATALOG NO.
HANDLE = ADD "H" TO END OF CATALOG NO.

Cambridge Brass considers the information in this submittal form to be correct at the time of publication. Item and option availability, including specifications, are subject to change without notice.

VALVE SIZE	CATALOG NO.	CB COMP.	P.E.P.	LENGTH	HEIGHT	APPROX. WT. LBS.
5/8"	204-H3Z3	3/4"	3/4"	3.82"	1.94"	

Submitted by: