

Cambridge Brass
P.O. Box 249
140 Orion Place
Cambridge, Ontario
Canada N1R 5V1
Tel: (519) 621-5520
Fax: (519) 621-8674
http://www.cambridgebrass.com

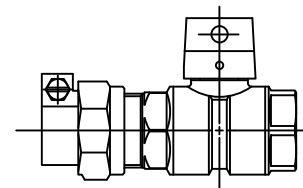

MODEL NO. 204

CAMPAK x FEMALE IRON PIPE

CURB STOP – BALL STYLE
REDUCED PORT

FOR COPPER OR PLASTIC TUBING (CTS) x THREADED PIPE

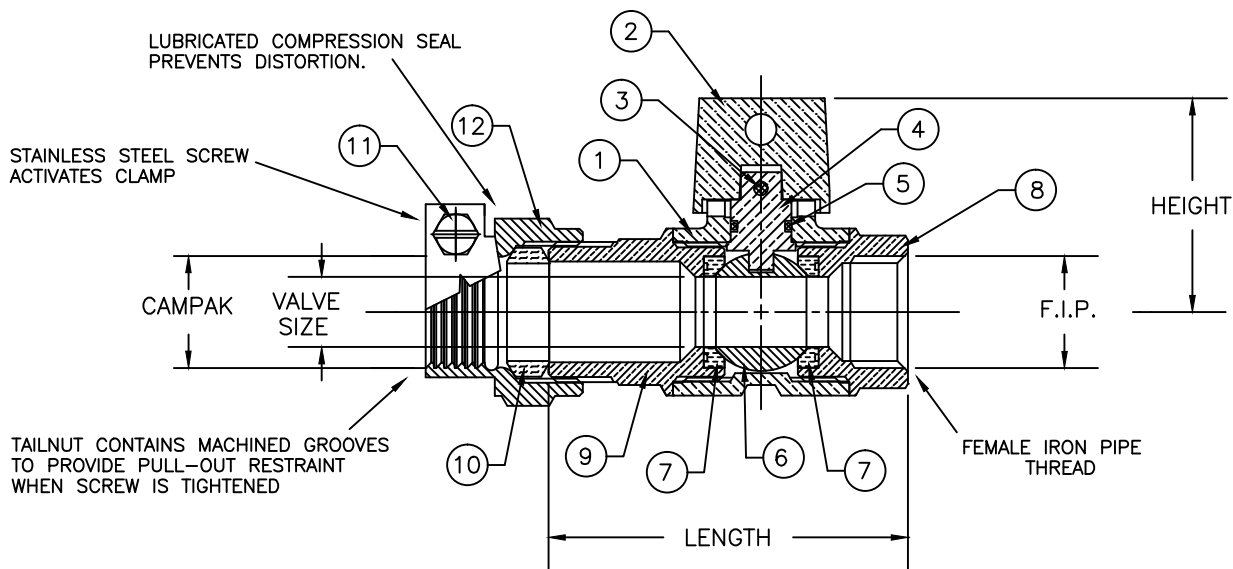

PARTS AND MATERIAL:

1. VALVE BODY: CAST BRASS, ALLOY C83600
2. CAP: CAST BRASS, ALLOY C84400
3. SPRING PIN: STAINLESS STEEL, TYPE 402
4. STEM: COPPER, ALLOY C83600
5. O-RING: NITRILE RUBBER
6. BALL: COPPER, ALLOY C83600, TEFLON COATED
7. SEATS: NITRILE RUBBER
8. FIP TAILPIECE: CAST BRASS, ALLOY C83600
9. COMPRESSION TAILPIECE: CAST BRASS, ALLOY C83600
10. COMPRESSION SEAL: NITRILE RUBBER
11. SCREW: STAINLESS STEEL, ALLOY 304
12. CAMPAK TAILNUT: CAST BRASS, ALLOY C83600

FEATURES:

- MANUFACTURED IN COMPLIANCE WITH AWWA STANDARD C800-05 (ASTM B-62 AND ASTM B-584, UNS NO C83600-85-5-5-5).
- FLOW CAN BE IN EITHER DIRECTION.
- BLOWOUT PROOF DESIGN.
- 300 PSI WORKING PRESSURE.
- ENCAPSULATED LUGS UNDER CAP PROVIDE 90 DEGREE OPEN TO CLOSE OPERATION.
- HOLE FOR ATTACHING CURB BOX ROD OR HANDLE IS PROVIDED IN CAP.

ORDERING INFORMATION:

FULL 360 ROTATION = ADD "R" TO END OF CATALOG NO.
HANDLE = ADD "H" TO END OF CATALOG NO.

Cambridge Brass considers the information in this submittal form to be correct at the time of publication. Item and option availability, including specifications, are subject to change without notice.

VALVE SIZE	CATALOG NO.	CAMPAK	F.I.P.	LENGTH	HEIGHT	APPROX. WT. LBS.
5/8"	204-B3F3	3/4"	3/4"	3.26"	1.94"	1.7

Submitted by: