

Cambridge Brass
P.O. Box 249
140 Orion Place
Cambridge, Ontario
Canada N1R 5V1
Tel: (519) 621-5520
Fax: (519) 621-8674
http://www.cambridgebrass.com

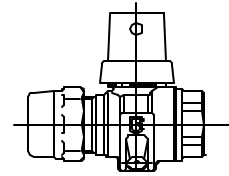

MODEL NO. 203

CB COMPRESSION x FEMALE IRON PIPE

CURB STOP – BALL STYLE
DRAINING

FOR COPPER OR PLASTIC TUBING (CTS) x THREADED PIPE

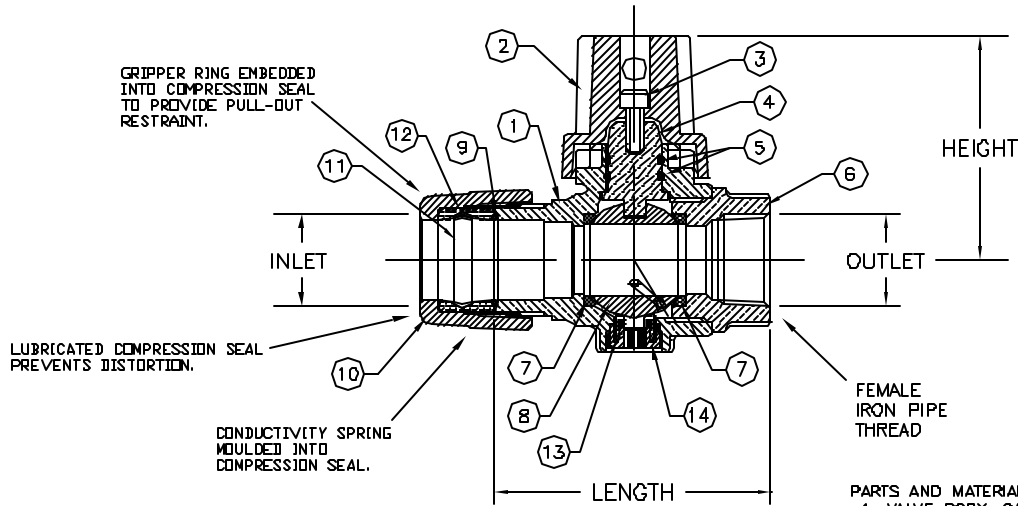

- PARTS AND MATERIAL:**
1. VALVE BODY: CAST BRASS, ALLOY C83600
 2. CAP: CAST BRASS, ALLOY C83600
 3. CAP SCREW: STAINLESS STEEL, TYPE 304
 4. STEM: STAINLESS STEEL, TYPE 303
 5. O-RING: NITRILE RUBBER
 6. ENDBODY: CAST BRASS, ALLOY C83600
 7. SEATS: TEFLON
 8. BALL: CAST BRASS, ALLOY C89833
 9. CONDUCTOR SPRING: BRASS
 10. TAILNUT: CAST BRASS, ALLOY C83600
 11. GRIPPER: STAINLESS STEEL, TYPE 302
 12. COMPRESSION SEAL: NITRILE RUBBER
 13. DRAIN SEAL: NITRILE RUBBER
 14. DRAIN PLUG: COPPER, ALLOY C36000

- FEATURES:**
- MANUFACTURED IN COMPLIANCE WITH AWWA STANDARD C800-D5 (ASTM B-62 AND ASTM B-584, UNS NO C83600-85-5-5-5).
 - <X> CSA CLASSIFIED TO ANSI/NSF STANDARD 61-8.
 - ROTATION STOPS RESISTS 200 FT-LB TORQUE.
 - ENCAPSULATED LUGS UNDER CAP PROVIDE 90 DEGREE OPEN TO CLOSE OPERATION.
 - HOLE FOR ATTACHING CURB BOX ROD OR HANDLE IS PROVIDED IN CAP.
 - BLOWOUT PROOF DESIGN.
 - 300 PSI WORKING PRESSURE.
 - VALVES ARE DIRECTIONAL (FLOW DIRECTION ARROWS PROVIDED ON BODY).

ORDERING INFORMATION:
FULL 360 ROTATION = ADD "R" TO END OF CATALOG NO.
HANDLE = ADD "H" TO END OF CATALOG NO.

Cambridge Brass considers the information in this submittal form to be correct at the time of publication. Item and option availability, including specifications, are subject to change without notice.

VALVE SIZE	CATALOG NO.	INLET CB COMP.	OUTLET F.I.P.	LENGTH	HEIGHT	APPROX. WT. LBS.	CLASSIFIED NSF 61-8
3/4"	203-H3F3	3/4"	3/4"	3.10"	2.50"	2.0	<X>
1"	203-H4F4	1"	1"	3.67"	2.68"	3.0	<X>
1 1/4"	203-H5F5	1 1/4"	1 1/4"	4.84"	3.31"	10.8	<X>
1 1/2"	203-H6F6	1 1/2"	1 1/2"	5.59"	3.31"	7.8	<X>
2"	203-H7F7	2"	2"	5.86"	3.61"	10.7	

Submitted by: