

Cambridge Brass
P.O. Box 249
140 Orion Place
Cambridge, Ontario
Canada N1R 5V1
Tel: (519) 621-5520
Fax: (519) 621-8674
http://www.cambridgebrass.com

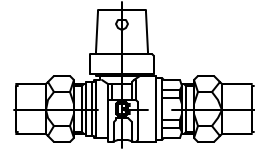

MODEL NO. 202

GRIP JOINT x GRIP JOINT

CURB STOP – BALL STYLE

FOR COPPER OR PLASTIC TUBING (CTS)

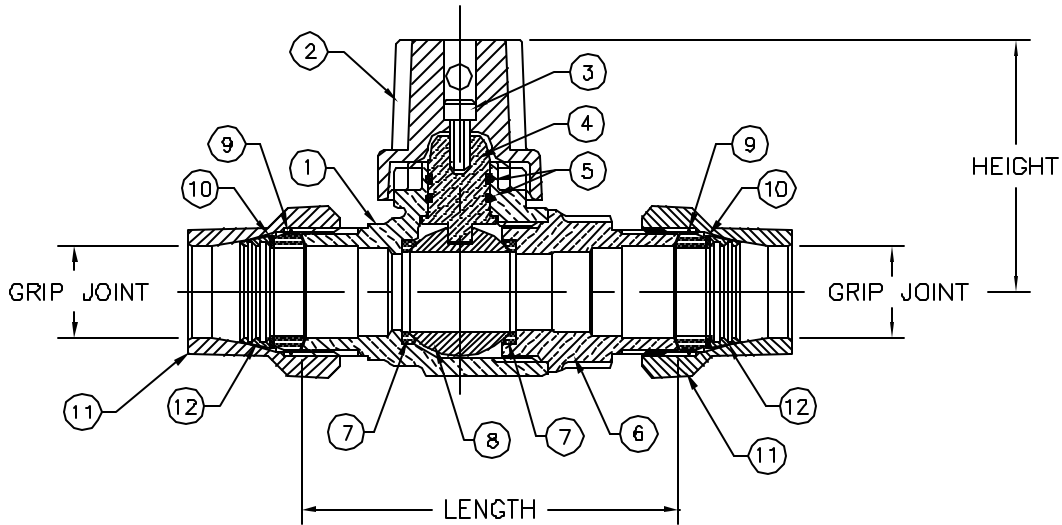

PARTS AND MATERIAL:

1. VALVE BODY: CAST BRASS, ALLOY C83600
2. CAP: CAST BRASS, ALLOY C83600
3. CAP SCREW: STAINLESS STEEL, TYPE 304
4. STEM: STAINLESS STEEL, TYPE 303
5. O-RING: NITRILE RUBBER
6. ENDBODY: CAST BRASS, ALLOY C83600
7. SEATS: TEFLON
8. BALL: CAST BRASS, ALLOY C89B33
9. GASKET: NITRILE RUBBER
10. WASHER: POLYETHYLENE
11. GRIP JOINT NUT: CAST BRASS, ALLOY C83600
12. GRIPPER: BRASS, ALLOY C26000

FEATURES:

- MANUFACTURED IN COMPLIANCE WITH AWWA STANDARD C800-05 (ASTM B-62 AND ASTM B-584, UNS NO C83600-85-5-5-5).
- CSA CLASSIFIED TO ANSI/NSF STANDARD 61-B.
- FLOW CAN BE IN EITHER DIRECTION.
- ROTATION STOPS RESISTS 200 FT-LB TORQUE.
- ENCAPSULATED LUGS UNDER CAP PROVIDE 90 DEGREE OPEN TO CLOSE OPERATION.
- HOLE FOR ATTACHING CURB BOX ROD OR HANDLE IS PROVIDED IN CAP.
- BLOWOUT PROOF DESIGN.
- 300 PSI WORKING PRESSURE.

ORDERING INFORMATION:

FULL 360 ROTATION = ADD "R" TO END OF CATALOG NO.
HANDLE = ADD "H" TO END OF CATALOG NO.

Cambridge Brass considers the information in this submittal form to be correct at the time of publication. Item and option availability, including specifications, are subject to change without notice.

VALVE SIZE	CATALOG NO.	GRIP JOINT	GRIP JOINT	LENGTH	HEIGHT	APPROX. WT. LBS.
3/4"	202-GJ3GJ3	3/4"	3/4"	3.75"	2.50"	
1"	202-GJ4GJ4	1"	1"	4.42"	2.68"	

Submitted by: