

Cambridge Brass
P.O. Box 249
140 Orion Place
Cambridge, Ontario
Canada N1R 5V1
Tel: (519) 621-5520
Fax: (519) 621-8674
http://www.cambridgebrass.com

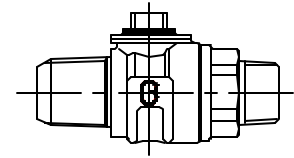

MODEL NO. 301NL

AWWA (CC) x MALE IRON PIPE

CORPORATION STOP
BALL STYLE

AWWA/CC TAPER THREAD INLET BY MALE IRON PIPE THREAD OUTLET

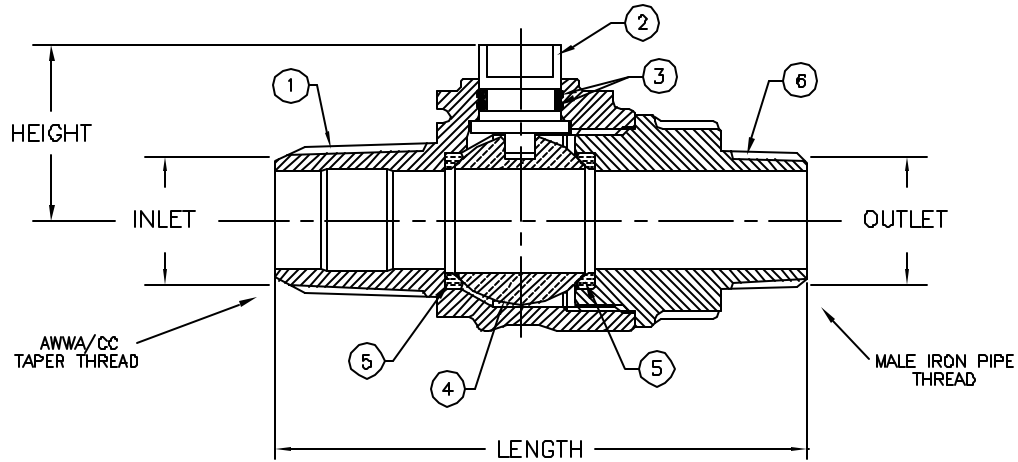

PARTS AND MATERIAL:

1. VALVE BODY: CAST BRASS, ALLOY C89833
2. STEM: STAINLESS STEEL, TYPE 303
3. O-RING: NITRILE RUBBER
4. BALL: CAST BRASS, ALLOY C89833
5. SEATS: TEFLON
6. ENDBODY: CAST BRASS, ALLOY C89833

FEATURES:

- ALL COMPONENTS CONFORM TO AWWA STANDARD C800-05 (ASTM B-584, UNS NO C89833 FOR BRASS PARTS IN CONTACT WITH POTABLE WATER, AND ASTM B-62 AND B-584, UNS NO C83600 FOR ALL OTHER BRASS PARTS).
- CSA CLASSIFIED TO ANSI/NSF STANDARD 61-8.
- BLOWOUT PROOF DESIGN.
- 300 PSI WORKING PRESSURE.
- BODY PROVIDES LARGE, RUGGED FLATS FOR PROPER INSTALLATION.
- FULL 360 DEGREE ROTATION.

Cambridge Brass considers the information in this submittal form to be correct at the time of publication. Item and option availability, including specifications, are subject to change without notice.

VALVE SIZE	CATALOG NO.	INLET AWWA/CC	OUTLET M.I.P.	LENGTH	HEIGHT	APPROX. WT. LBS.
3/4"	301NL-A3M3	3/4"	3/4"	4.05"	1.33"	1.4
1"	301NL-A4M4	1"	1"	4.71"	1.51"	2.2
1 1/2"	301NL-A6M6	1 1/2"	1 1/2"	6.40"	2.17"	6.4
1 1/2"	301NL-A6M7	1 1/2"	2"	6.56"	2.17"	7.2
2"	301NL-A7M7	2"	2"	6.78"	2.47"	9.3

Submitted by: