

Cambridge Brass
P.O. Box 249
140 Orion Place
Cambridge, Ontario
Canada N1R 5V1
Tel: (519) 621-5520
Fax: (519) 621-8674
http://www.cambridgebrass.com

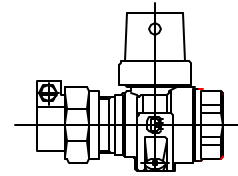

MODEL NO. 253

CAMPAK x FEMALE IRON PIPE

CURB STOP – BALL STYLE
DRAINING
OPEN RIGHT

FOR COPPER OR PLASTIC TUBING (CTS) x THREADED PIPE

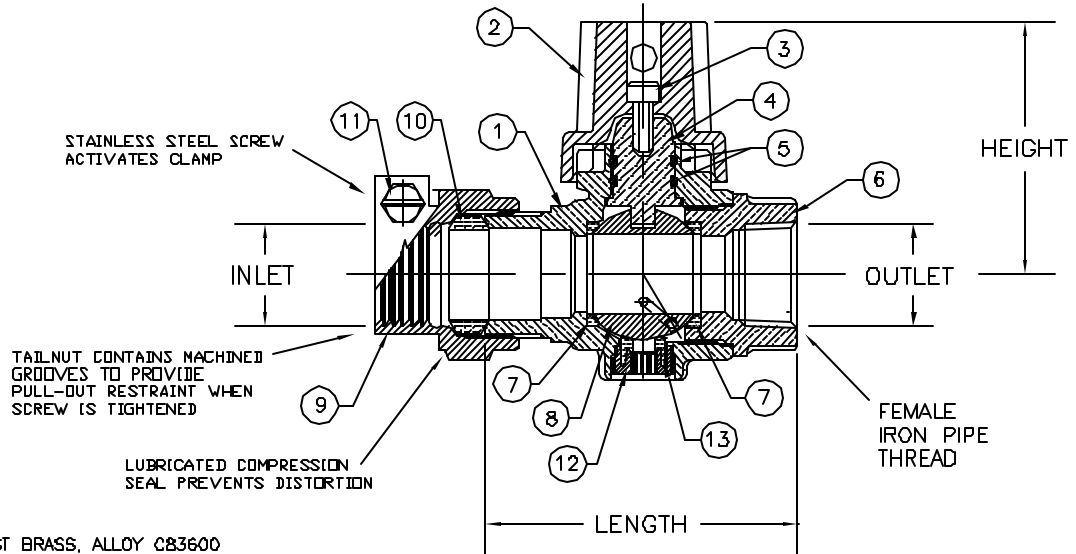

PARTS AND MATERIAL:

1. VALVE BODY: CAST BRASS, ALLOY C83600
2. CAP: CAST BRASS, ALLOY C83600
3. CAP SCREW: STAINLESS STEEL, TYPE 304
4. STEM: STAINLESS STEEL, TYPE 303
5. O-RING: NITRILE RUBBER
6. ENDBODY: CAST BRASS, ALLOY C83600
7. SEATS: TEFLON
8. BALL: CAST BRASS, ALLOY C89833
9. TAILNUT: CAST BRASS, ALLOY C83600
10. COMPRESSION SEAL: NITRILE RUBBER
11. SCREW: STAINLESS STEEL, ALLOY 304
12. DRAIN PLUG: COPPER, ALLOY C36000
13. DRAIN SEAL: NITRILE RUBBER

FEATURES:

- MANUFACTURED IN COMPLIANCE WITH AWWA STANDARD C800-05 (ASTM B-82 AND ASTM B-584, UNS NO C83600-85-5-5-5).
- <X> CSA CLASSIFIED TO ANSI/NSF STANDARD 61-8.
- ROTATION STOPS RESISTS 200 FT-LB TORQUE.
- ENCAPSULATED LUGS UNDER CAP PROVIDE 90 DEGREE OPEN TO CLOSE OPERATION.
- HOLE FOR ATTACHING CURB BOX ROD OR HANDLE IS PROVIDED IN CAP.
- BLOWOUT PROOF DESIGN.
- 300 PSI WORKING PRESSURE.
- VALVES ARE DIRECTION (FLOW DIRECTION ARROWS PROVIDED ON BODY).

ORDERING INFORMATION:
HANDLE - ADD "H" TO END OF CATALOG NO.

Cambridge Brass considers the information in this submittal form to be correct at the time of publication. Item and option availability, including specifications, are subject to change without notice.

VALVE INLET	CATALOG NO.	INLET CAMPAK	OUTLET F.I.P.	LENGTH	HEIGHT	APPROX. WT. LBS.	CLASSIFIED NSF 61-8
3/4"	253-B3F3	3/4"	3/4"	3.10"	2.50"		<X>
1"	253-B4F4	1"	1"	3.67"	2.68"		<X>
1 1/2"	253-B6F6	1 1/2"	1 1/2"	5.59"	3.31"		<X>
2"	253-B7F7	2"	2"	5.86"	3.61"		

Submitted by: