

Cambridge Brass  
P.O. Box 249  
140 Orion Place  
Cambridge, Ontario  
Canada N1R 5V1  
Tel: (519) 621-5520  
Fax: (519) 621-8674  
http://www.cambridgebrass.com

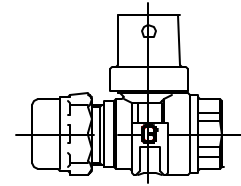

MODEL NO. 252NL

CB COMPRESSION x FEMALE IRON PIPE

CURB STOP - BALL STYLE  
OPEN RIGHT

FOR COPPER OR PLASTIC TUBING (CTS) x THREADED PIPE

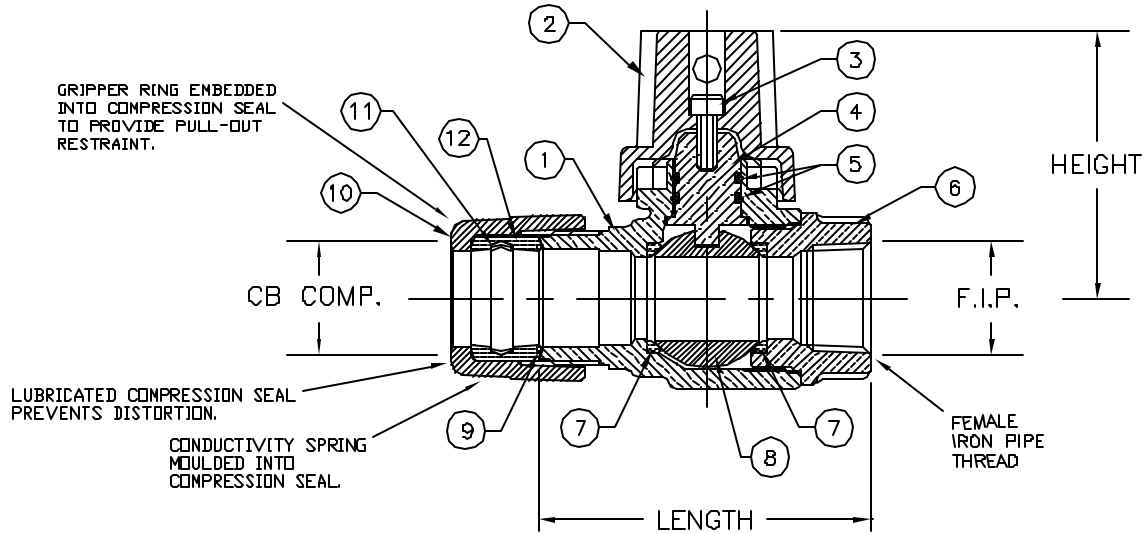

- PARTS AND MATERIAL:
1. VALVE BODY: CAST BRASS, ALLOY C89833
  2. CAP: CAST BRASS, ALLOY C83600
  3. CAP SCREW: STAINLESS STEEL, TYPE 304
  4. STEM: STAINLESS STEEL, TYPE 303
  5. O-RING: NITRILE RUBBER
  6. ENDBODY: CAST BRASS, ALLOY C89833
  7. SEATS: TEFLON
  8. BALL: CAST BRASS, ALLOY C89833
  9. CONDUCTOR SPRING: BRASS
  10. TAILNUT: CAST BRASS, ALLOY C83600
  11. GRIPPER: STAINLESS STEEL, TYPE 302
  12. COMPRESSION SEAL: NITRILE RUBBER

- FEATURES:
- MANUFACTURED IN COMPLIANCE WITH ANWA STANDARD C800-05. (ASTM B-584, UNS NO C89833).
  - CSA CLASSIFIED TO ANSI/NSF STANDARD 81-B.
  - FLOW CAN BE IN EITHER DIRECTION.
  - ROTATION STOPS RESISTS 200 FT-LB TORQUE.
  - ENCAPSULATED LUGS UNDER CAP PROVIDE 90 DEGREE OPEN TO CLOSE OPERATION.
  - HOLE FOR ATTACHING CURB BOX ROD OR HANDLE IS PROVIDED IN CAP.
  - BLOWOUT PROOF DESIGN.
  - 300 PSI WORKING PRESSURE.

ORDERING INFORMATION:  
HANDLE - ADD "H" TO END OF CATALOG NO.

Cambridge Brass considers the information in this submittal form to be correct at the time of publication. Item and option availability, including specifications, are subject to change without notice.

VALVE SIZE	CATALOG NO.	CB COMP.	F.I.P.	LENGTH	HEIGHT	APPROX. WT. LBS.
3/4"	252NL-H3F3	3/4"	3/4"	3.10"	2.50"	2.1
1"	252NL-H4F4	1"	1"	3.67"	2.68"	3.1
1 1/2"	252NL-H6F6	1 1/2"	1 1/2"	5.59"	3.31"	7.8
2"	252NL-H7F7	2"	2"	5.86"	3.61"	10.7

Submitted by: