

Cambridge Brass
 P.O. Box 249
 140 Orion Place
 Cambridge, Ontario
 Canada N1R 5V1
 Tel: (519) 621-5520
 Fax: (519) 621-8674
 http://www.cambridgebrass.com

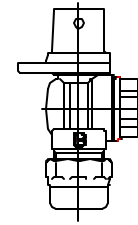

MODEL NO. 210

CB COMPRESSION x FEMALE IRON PIPE

ANGLE METER VALVE – BALL STYLE
 FULL PORT WITH LOCKWING

FOR COPPER OR PLASTIC TUBING (CTS) x THREADED PIPE

PARTS AND MATERIAL:

1. VALVE BODY: CAST BRASS, ALLOY C83600
2. LOCKING CAP: CAST BRASS, ALLOY C83600
3. CAP SCREW: STAINLESS STEEL, TYPE 304
4. STEM: STAINLESS STEEL, TYPE 303
5. O-RING: NITRILE RUBBER
6. ENDBODY: CAST BRASS, ALLOY C83600
7. SEATS: TEFLON
8. BALL: CAST BRASS, ALLOY C89833
9. CONDUCTOR SPRING: BRASS
10. TAILNUT: CAST BRASS, ALLOY C83600
11. GRIPPER: STAINLESS STEEL, TYPE 302
12. COMPRESSION SEAL: NITRILE RUBBER

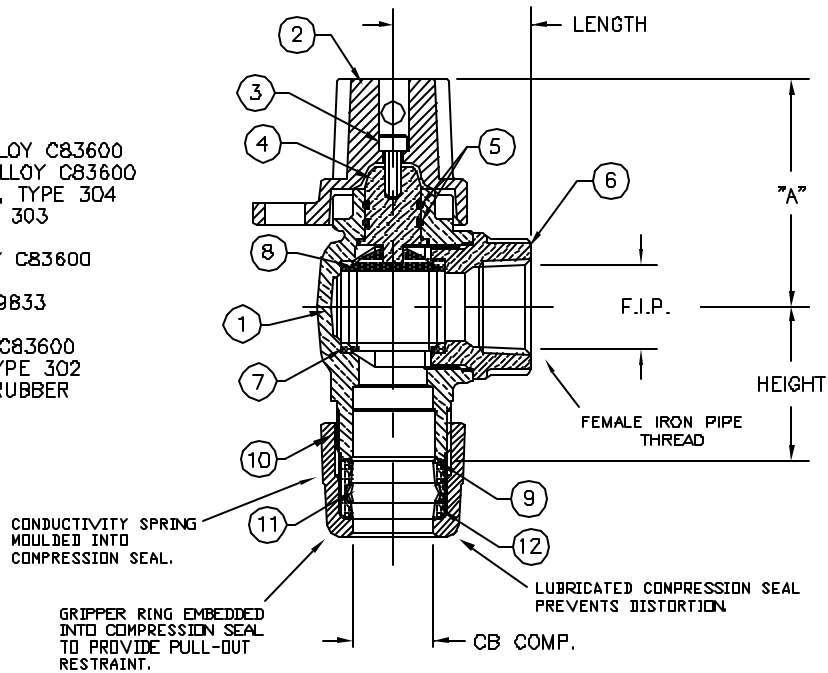

FEATURES:

- MANUFACTURED IN COMPLIANCE WITH AWWA STANDARD C800-05 (ASTM B-62 AND ASTM B-584, UNS NO C83600-B5-5-5-5).
- CSA CLASSIFIED TO ANSI/NSF STANDARD 61-8.
- FLOW CAN BE IN EITHER DIRECTION.
- ROTATION STOPS RESISTS 200 FT-LB TORQUE.
- ENCAPSULATED LUGS UNDER CAP PROVIDE 90 DEGREE OPEN TO CLOSE OPERATION.
- BLOWOUT PROOF DESIGN.
- 300 PSI WORKING PRESSURE.
- HOLE FOR ATTACHING HANDLE IS PROVIDED IN CAP.
- PADLOCK WING FOR LOCKING VALVE IN CLOSED POSITION.

ORDERING INFORMATION:

FULL 360 ROTATION = ADD "R" TO END OF CATALOG NO.
 HANDLE = ADD "H" TO END OF CATALOG NO.

Cambridge Brass considers the information in this submittal form to be correct at the time of publication. Item and option availability, including specifications, are subject to change without notice.

| VALVE SIZE | CATALOG NO. | CB COMP. | F.I.P. | HEIGHT | LENGTH | "A" | APPROX. WT. LBS. |
|------------|-------------|----------|--------|--------|--------|-------|------------------|
| 3/4" | 210-H3F3 | 3/4" | 3/4" | 1.69" | 1.53" | 2.50" | 2.1 |
| 3/4" | 210-H4F3 | 1" | 3/4" | 2.17" | 1.53" | 2.50" | |
| 1" | 210-H4F4 | 1" | 1" | 1.97" | 1.78" | 2.68" | 3.0 |

Submitted by: