

Cambridge Brass
P.O. Box 249
140 Orion Place
Cambridge, Ontario
Canada N1R 5V1
Tel: (519) 621-5520
Fax: (519) 621-8674
http://www.cambridgebrass.com

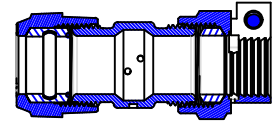

MODEL NO. 119NL

CB COMPRESSION X
XS LEAD COMPRESSION

COUPLING – FULL BORE

FOR COPPER OR PLASTIC TUBING (CTS) X LEAD PIPE (XS)

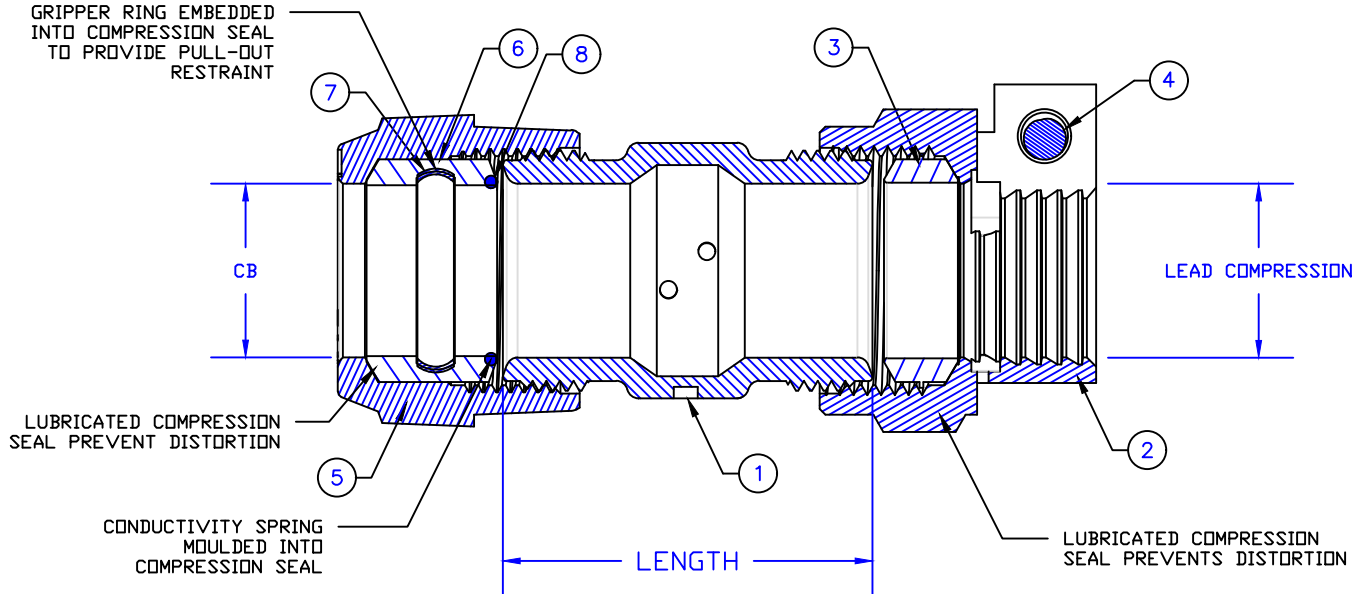

PARTS AND MATERIAL:

1. COUPLING BODY: CAST BRASS, ALLOY C89833
2. CAMPAK NUT: CAST BRASS, ALLOY C83600
3. COMPRESSION SEAL: NITRILE RUBBER
4. SCREW: STAINLESS STEEL, TYPE 304
5. COMPRESSION NUT: CAST BRASS, ALLOY C83600
6. COMPRESSION SEAL: EPDM
7. GRIPPER: STAINLESS STEEL, TYPE 302
8. CONDUCTOR SPRING: BRASS

FEATURES:

- ALL COMPONENTS CONFORM TO AWWA STANDARD C800-05 (ASTM B-584 UNS NO C89833 FOR BRASS PARTS IN CONTACT WITH POTABLE WATER, AND ASTM B-62 AND B-584 UNS NO C83600 FOR ALL OTHER BRASS PARTS).
- CONFORMS TO ANSI/NSF 61-8
- CONFORMS TO ANSI/NSF 372 (COMPLIANT WITH US Safe Drinking Water Act. PL 111-380)
- 300 PSI WORKING PRESSURE.
- BODY PROVIDES LARGE, RUGGED FLATS FOR PROPER INSTALLATION.

Cambridge Brass considers the information in this submittal form to be correct at the time of publication. Item and option availability, including specifications, are subject to change without notice.

CATALOG NO.	CB COMPRESSION	XS LEAD COMPRESSION	LENGTH	APPROX. WT. LBS.
119NL-H3XS1	3/4"	1/2"	1.93"	1.0
119NL-H3XS2	3/4"	5/8"	2.13"	1.0
119NL-H4XS2	1"	5/8"	2.13"	1.2
119NL-H4XS4	1"	1"	2.36	1.5

Submitted by: