

Cambridge Brass
P.O. Box 249
140 Orion Place
Cambridge, Ontario
Canada N1R 5V1
Tel: (519) 621-5520
Fax: (519) 621-8674
http://www.cambridgebrass.com

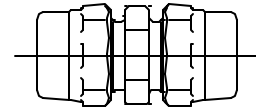

MODEL NO. 119NL

CB COMPRESSION x CB COMPRESSION

COUPLING – FULL BORE

FOR COPPER OR PLASTIC TUBING (CTS)

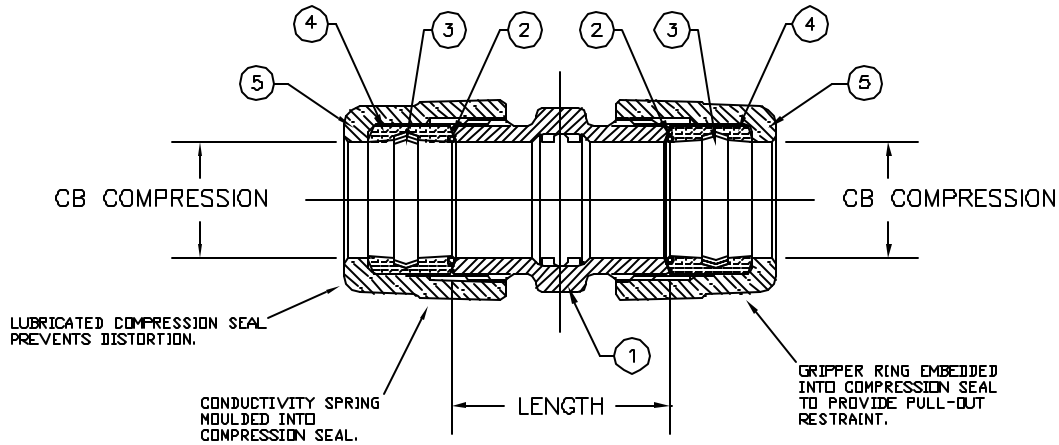

PARTS AND MATERIAL:

1. COUPLING BODY: CAST BRASS, ALLOY C89B33
2. CONDUCTOR SPRING: BRASS
3. GRIPPER: STAINLESS STEEL, TYPE 302
4. COMPRESSION SEAL: NITRILE RUBBER
5. COMPRESSION NUT: CAST BRASS, ALLOY C83600

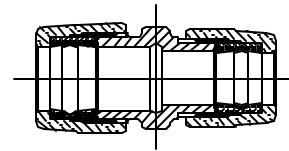

119-H4H3 CONFIGURATION

FEATURES:

- MANUFACTURED IN COMPLIANCE WITH AWWA STANDARD C800.
- BODY PROVIDES LARGE, RUGGED WRENCH FLATES FOR PROPER INSTALLATION.

Cambridge Brass considers the information in this submittal form to be correct at the time of publication. Item and option availability, including specifications, are subject to change without notice.

CATALOG NO.	CB COMPRESSION	CB COMPRESSION	LENGTH	APPROX. WT. LBS.
119NL-H3H3	3/4"	3/4"	1.70"	
119NL-H4H3	1"	3/4"	2.00"	
119NL-H4H4	1"	1"	2.00"	
119NL-H5H5	1 1/4"	1 1/4"	3.07"	
119NL-H6H6	1 1/2"	1 1/2"	2.78"	
119NL-H7H7	2"	2"	3.04"	

Submitted by: