

Cambridge Brass
P.O. Box 249
140 Orion Place
Cambridge, Ontario
Canada N1R 5V1
Tel: (519) 621-5520
Fax: (519) 621-8674
http://www.cambridgebrass.com

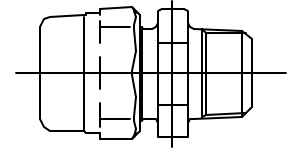

MODEL NO. 117

CB COMPRESSION x
MALE IRON PIPE

ADAPTOR

FOR COPPER OR PLASTIC (CTS) TUBING x THREADED PIPE

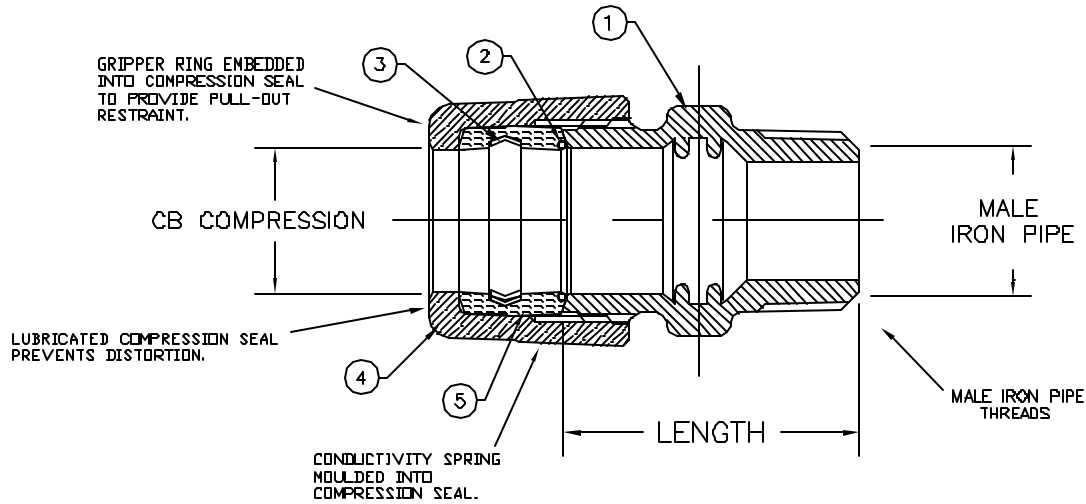

- PARTS AND MATERIAL:
1. BODY: CAST BRASS, ALLOY C83600
 2. CONDUCTOR SPRING: BRASS
 3. GRIPPER: STAINLESS STEEL, TYPE 302
 4. COMPRESSION NUT: CAST BRASS, ALLOY C83600
 5. COMPRESSION SEAL: NITRILE RUBBER

- FEATURES:
- MANUFACTURED IN COMPLIANCE WITH AWWA STANDARD C800-D5 (ASTM B-62 AND ASTM B-584, UNS NO C83600-85-5-5-5).
 - <X> CSA CLASSIFIED TO ANSI/NSF STANDARD 61-8.
 - BODY PROVIDES LARGE, RUGGED WRENCH FLATS FOR PROPER INSTALLATION.

Cambridge Brass considers the information in this submittal form to be correct at the time of publication. Item and option availability, including specifications, are subject to change without notice.

COUPLING SIZE	CATALOG NO.	CB COMPRESSION	MALE IRON PIPE	LENGTH	APPROX. WT. LBS.	CLASSIFIED NSF 61-8
3/4" x 1/2"	117-H3M1	3/4"	1/2"	1.76"	0.7	X
3/4"	117-H3M3	3/4"	3/4"	1.86"	0.7	X
3/4" x 1"	117-H3M4	3/4"	1"	1.99"	0.8	X
1" x 3/4"	117-H4M3	1"	3/4"	2.02"	1.1	X
1"	117-H4M4	1"	1"	2.08"	1.1	X
1 1/4"	117-H5M5	1 1/4"	1 1/4"	2.83"	2.6	X
1 1/2"	117-H6M6	1 1/2"	1 1/2"	2.53"	2.0	X
2"	117-H7M7	2"	2"	3.01"	2.8	

Submitted by: