

Cambridge Brass
P.O. Box 249
140 Orion Place
Cambridge, Ontario
Canada N1R 5V1
Tel: (519) 621-5520
Fax: (519) 621-8674
http://www.cambridgebrass.com

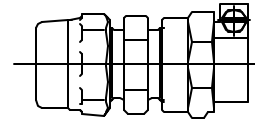

MODEL NO. 118

CB COMPRESSION x LEAD PIPE

COUPLING

FOR COPPER OR PLASTIC TUBING (CTS) x LEAD PIPE (XS)

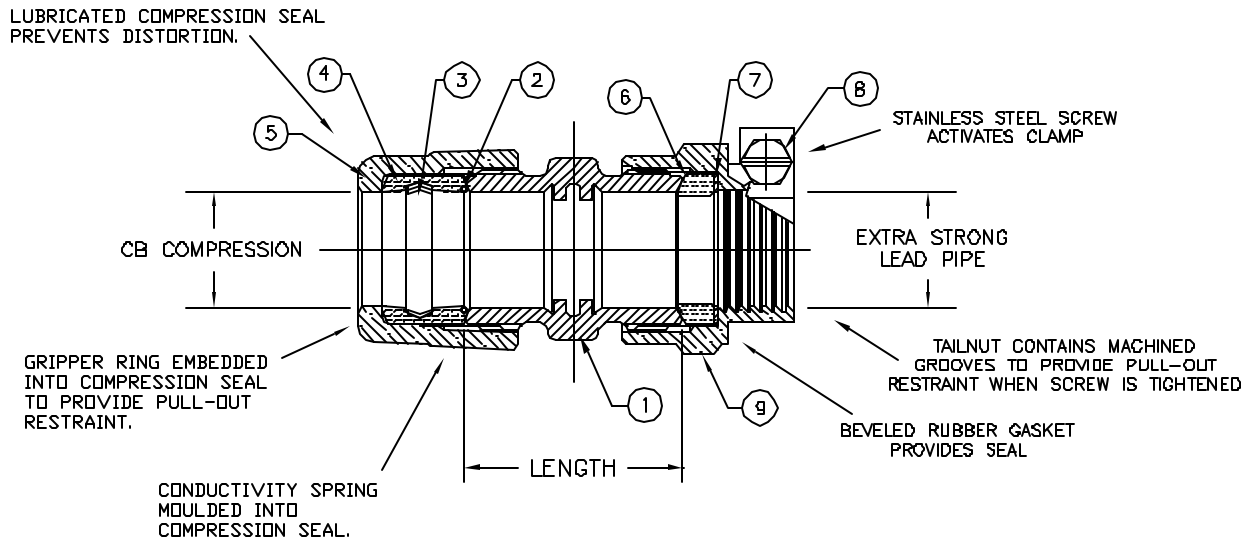

PARTS AND MATERIAL:

1. COUPLING BODY: CAST BRASS, ALLOY C83600
2. CONDUCTOR SPRING: BRASS
3. GRIPPER: STAINLESS STEEL, TYPE 302
4. COMPRESSION SEAL: NITRILE RUBBER
5. COMPRESSION NUT: CAST BRASS, ALLOY C83600
6. GASKET: RUBBER COMPOUND NSF-61
7. ANTI-FRICTION WASHER: HDPE
8. SCREW: STAINLESS STEEL, ALLOY 304
9. NUT: CAST BRASS, ALLOY C83600

FEATURES:

- MANUFACTURED IN COMPLIANCE WITH AWWA STANDARD C800-05 (ASTM B-82 AND ASTM B-584, UNS NO C83600-85-5-5-5).
- <X> CSA CLASSIFIED TO ANSI/NSF STANDARD 61-8.
- BODY DESIGN PROVIDES LARGE, RUGGED WRENCH FLATES FOR PROPER INSTALLATION.
- BODY PROVIDES INTERNAL TUBE STOP.

Cambridge Brass considers the information in this submittal form to be correct at the time of publication. Item and option availability, including specifications, are subject to change without notice.

CATALOG NO.	CB COMPRESSION	EXTRA STRONG LEAD PIPE	LENGTH	APPROX. WT. LBS.	CLASSIFIED NSF 61-8
118-H4XS2	1"	5/8"	2.1"		X

Submitted by: