

Cambridge Brass
P.O. Box 249
140 Orion Place
Cambridge, Ontario
Canada N1R 5V1
Tel: (519) 621-5520
Fax: (519) 621-8674
http://www.cambridgebrass.com

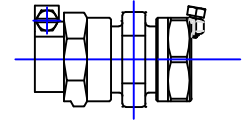

MODEL NO. 119

PEP x IRON PIPE

COUPLING – FULL BORE

FOR POLYETHYLENE PIPE X IRON PIPE

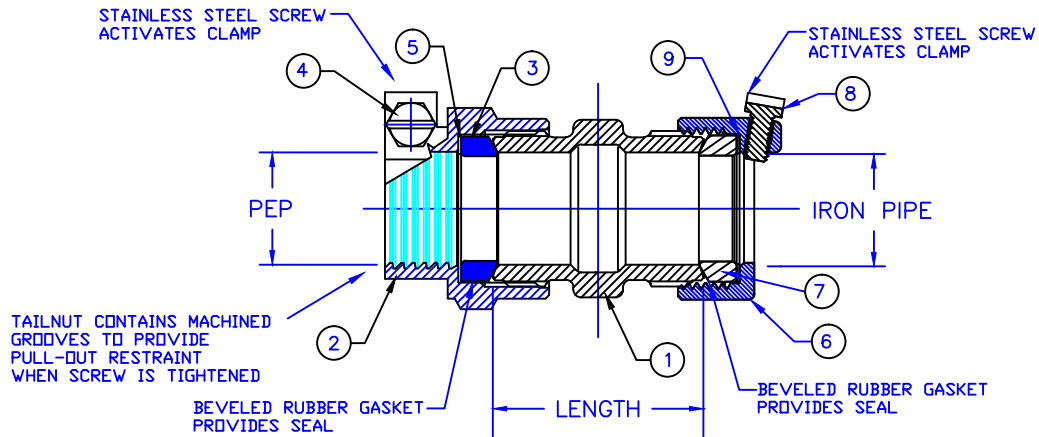

PARTS AND MATERIAL:

1. COUPLING BODY: CAST BRASS, ALLOY C83600
2. PEP NUT: CAST BRASS, ALLOY C83600
3. GASKET: RUBBER COMPOUND NSF-61
4. SCREW: STAINLESS STEEL, TYPE 304
5. ANTI-FRICTION WASHER: HDPE
6. IRON PIPE NUT: CAST BRASS, ALLOY C83600
7. GASKET: RUBBER COMPOUND NSF-61
8. SCREW: STAINLESS STEEL, TYPE 304
9. ANTI-FRICTION WASHER: HDPE

FEATURES:

- MANUFACTURED IN COMPLIANCE WITH AWWA STANDARD C800-05 (ASTM B-62 AND ASTM B-584, UNS NO C83600-85-5-5-5).
- BODY PROVIDES LARGE, RUGGED WRENCH FLATES FOR PROPER INSTALLATION.

Cambridge Brass considers the information in this submittal form to be correct at the time of publication. Item and option availability, including specifications, are subject to change without notice.

CATALOG NO.	PEP SIZE	IRON PIPE SIZE	LENGTH	APPROX. WT. LBS.
119-PE3IP3	3/4"	3/4"	2.12"	
119-PE3IP4	3/4"	1"		
119-PE4IP3	1"	3/4"		
119-PE4IP4	1"	1"	3.07"	

Submitted by: