

Cambridge Brass
P.O. Box 249
140 Orion Place
Cambridge, Ontario
Canada N1R 5V1
Tel: (519) 621-5520
Fax: (519) 621-8674
http://www.cambridgebrass.com

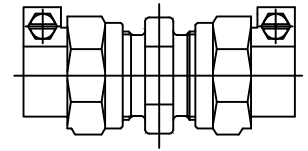

MODEL NO. 118NL

CAMPAK x CAMPAK

COUPLING
WITH INTERNAL STOPS

FOR COPPER OR PLASTIC (CTS) TUBING

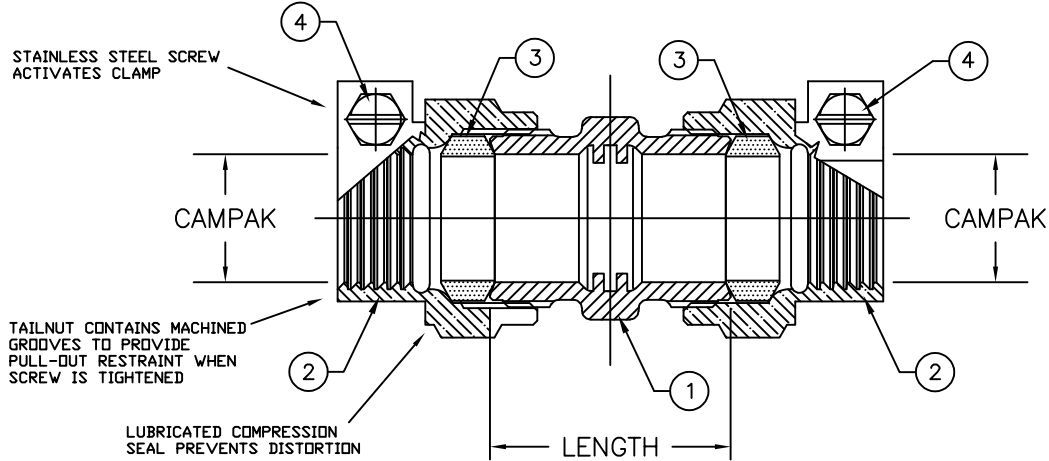

PARTS AND MATERIAL:

1. COUPLING BODY: CAST BRASS, ALLOY C89833
2. CAMPAK NUT: CAST BRASS, ALLOY C83600
3. COMPRESSION SEAL: NITRILE RUBBER
4. SCREW: STAINLESS STEEL, TYPE 304

FEATURES:

- CONFORMS TO AWWA C800 (ASTM B584 UNS C89833 FOR ALL BRASS PARTS IN CONTACT WITH POTABLE WATER)
- CONFORMS TO ANSI/NSF 61-8
- CONFORMS TO ANSI/NSF 372 (COMPLIANT WITH US Safe Drinking Water Act. PL 111-380)
- BODY AND NUTS PROVIDE WRENCH FLATS FOR INSTALLATION
- BODY PROVIDES INTERNAL TUBE STOPS.
- 300PSI WORKING PRESSURE

Cambridge Brass considers the information in this submittal form to be correct at the time of publication. Item and option availability, including specifications, are subject to change without notice.

CATALOG NO.	CAMPAK SIZE	CAMPAK SIZE	LENGTH	APPROX. WT. LBS.
118NL-B2B1	5/8"	1/2"	2.10"	1.0
118NL-B3B1	3/4"	1/2"	1.90"	1.0
118NL-B3B2	3/4"	5/8"	1.92"	1.0
118NL-B3B3	3/4"	3/4"	1.93"	1.0
118NL-B4B2	1"	5/8"	2.03"	1.3
118NL-B4B3	1"	3/4"	2.10"	1.4
118NL-B4B4	1"	1"	2.12"	1.5
118NL-B5B5	1 1/4"	1 1/4"	3.07"	2.1
118NL-B6B6	1 1/2"	1 1/2"	2.78"	3.7
118NL-B7B7	2"	2"	3.04"	5.3

Submitted by: