

Cambridge Brass
P.O. Box 249
140 Orion Place
Cambridge, Ontario
Canada N1R 5V1
Tel: (519) 621-5520
Fax: (519) 621-8674
http://www.cambridgebrass.com

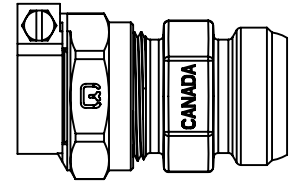

MODEL NO. 117NL

PEP x COPPER PIPE

ADAPTOR

FOR POLYETHYLENE PIPE (PEP) x COPPER PIPE

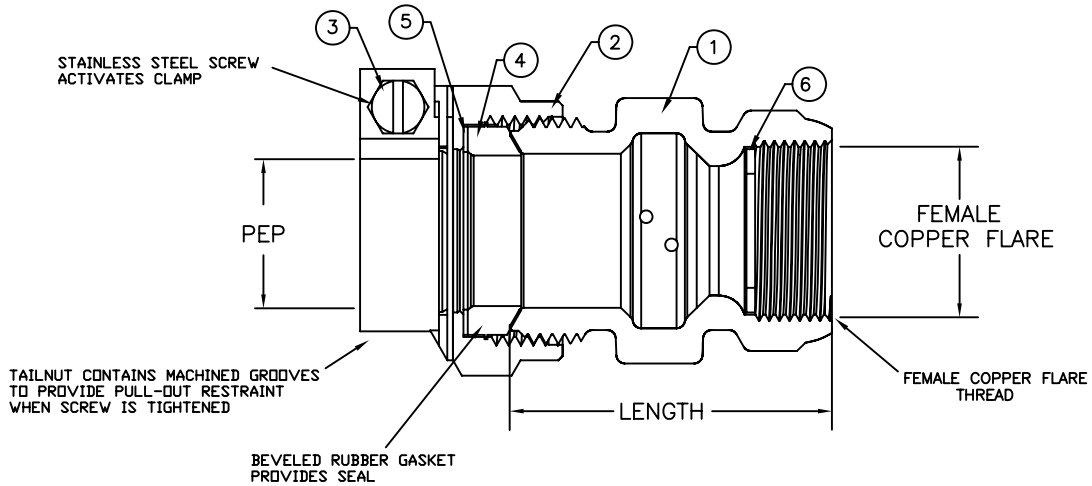

PARTS AND MATERIAL:

1. COUPLING BODY: NO LEAD CAST BRASS, ALLOY C89833
2. PEP NUT: CAST BRASS, ALLOY C83600
3. SCREW: STAINLESS STEEL, ALLOY 304
4. GASKET: RUBBER COMPOUND NSF-61
5. ANTI-FRICTION WASHER: HDPE
6. COPPER WASHER

FEATURES:

- MANUFACTURED IN COMPLIANCE WITH AWWA STANDARD C800-05 (ASTM B-62 AND ASTM B-584, UNS NO C83600-85-5-5-5).
- <X> CSA CLASSIFIED TO ANSI/NSF STANDARD 61-8.
- BODY PROVIDES LARGE, RUGGED WRENCH FLATS FOR PROPER INSTALLATION.

Cambridge Brass considers the information in this submittal form to be correct at the time of publication. Item and option availability, including specifications, are subject to change without notice.

COUPLING SIZE	CATALOG NO.	PEP	COPPER PIPE	LENGTH	APPROX. WT. LBS.	CLASSIFIED NSF 61-8
3/4"	117NL-PE3P3	3/4"	3/4"	2.28"		X

Submitted by: