

Cambridge Brass  
P.O. Box 249  
140 Orion Place  
Cambridge, Ontario  
Canada N1R 5V1  
Tel: (519) 621-5520  
Fax: (519) 621-8674  
http://www.cambridgebrass.com

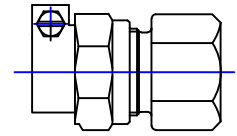

MODEL NO. 117NL

CAMPAK x FEMALE IRON PIPE

ADAPTOR

FOR COPPER OR PLASTIC TUBING (CTS) x THREADED PIPE

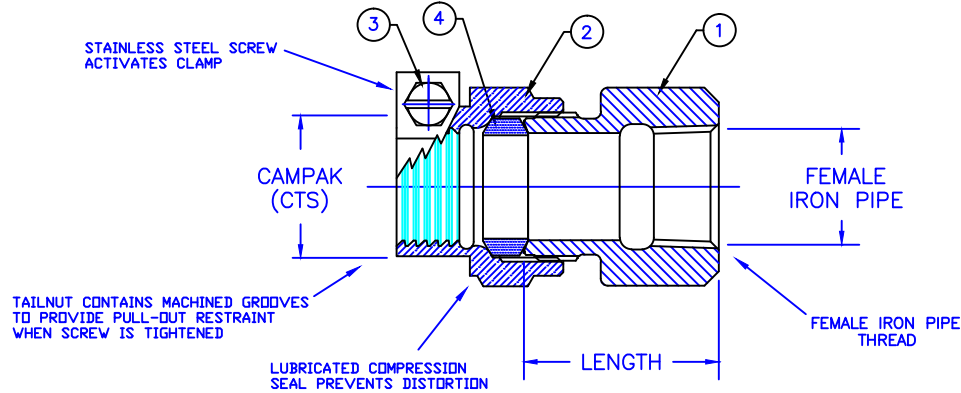

- PARTS AND MATERIAL:
1. BODY: CAST BRASS, ALLOY C89833
  2. CAMPAK NUT: CAST BRASS, ALLOY C83600
  3. SCREW: STAINLESS STEEL, ALLOY 304
  4. COMPRESSION SEAL: NITRILE RUBBER

**FEATURES:**

- CONFORMS TO AWWA C800 (ASTM B584 UNS C89833 FOR ALL BRASS PARTS IN CONTACT WITH POTABLE WATER)
- CONFORMS TO ANSI/NSF 61-8
- CONFORMS TO ANSI/NSF 372 (COMPLIANT WITH US Safe Drinking Water Act. PL 111-380)
- BODY AND NUTS PROVIDE WRENCH FLATS FOR INSTALLATION
- 300PSI WORKING PRESSURE

Cambridge Brass considers the information in this submittal form to be correct at the time of publication. Item and option availability, including specifications, are subject to change without notice.

COUPLING SIZE	CATALOG NO.	CAMPAK (CTS)	FEMALE IRON PIPE	LENGTH	APPROX. WT. LBS.
1/2" x 1/2"	117NL-B1F1	1/2"	1/2"	2.18"	0.6
5/8" x 3/4"	117NL-B2F3	5/8"	3/4"	1.51"	0.5
3/4" x 1/2"	117NL-B3F1	3/4"	1/2"	1.59"	0.9
3/4"	117NL-B3F3	3/4"	3/4"	1.65"	0.7
3/4" x 1"	117NL-B3F4	3/4"	1"	1.74"	1.2
1" x 3/4"	117NL-B4F3	1"	3/4"	1.84"	1.2
1"	117NL-B4F4	1"	1"	1.84"	1.1
1 1/2"	117NL-B6F6	1 1/2"	1 1/2"	2.77"	2.6
2"	117NL-B7F7	2"	2"	2.70"	3.8

Submitted by: