

Cambridge Brass
P.O. Box 249
140 Orion Place
Cambridge, Ontario
Canada N1R 5V1
Tel: (519) 621-5520
Fax: (519) 621-8674
http://www.cambridgebrass.com

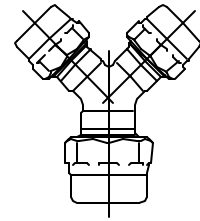

MODEL NO. 152

CB COMPRESSION x CB COMPRESSION
x CB COMPRESSION

WYE – BRANCH

FOR COPPER OR PLASTIC (CTS) TUBING

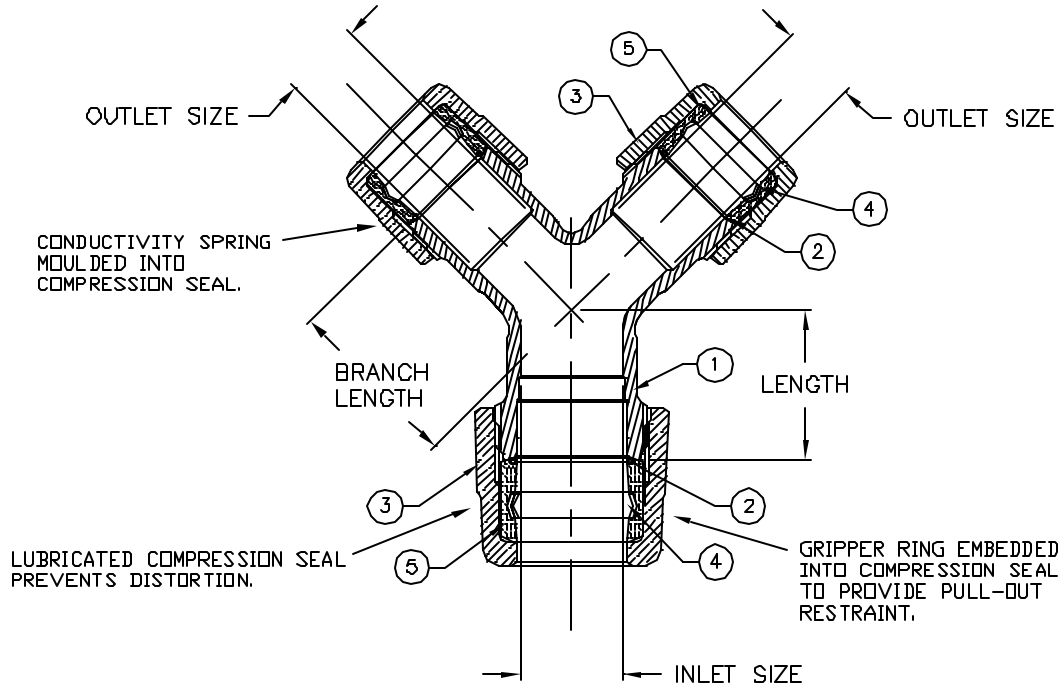

- PARTS AND MATERIAL:
1. BODY: CAST BRASS, ALLOY C83600
 2. CONDUCTOR SPRING: BRASS
 3. COMPRESSION NUT: CAST BRASS, ALLOY C83600
 4. GRIPPER: STAINLESS STEEL, TYPE 302
 5. COMPRESSION SEAL: NITRILE RUBBER

FEATURES:
- MANUFACTURED IN COMPLIANCE WITH AWWA STANDARD C800-05 (ASTM B-62 AND ASTM B-584, UNS NO C83600-85-5-5-5).
- <X> CSA CLASSIFIED TO ANSI/NSF STANDARD 61-8.

Cambridge Brass considers the information in this submittal form to be correct at the time of publication. Item and option availability, including specifications, are subject to change without notice.

| SIZE | CATALOG NO. | INLET SIZE | OUTLET SIZE | LENGTH | BRANCH LENGTH | APPROX. WT. LBS. | CLASSIFIED NSF 61-8 |
|------------------|-------------|------------|-------------|--------|---------------|------------------|---------------------|
| 1" x 3/4" x 3/4" | 152-H4H3 | 1" | 3/4" | 1.56" | 1.83" | | X |
| 1 1/2" x 1" x 1" | 152-H6H4 | 1 1/2" | 1" | 2.75" | 1.44" | | X |
| 2" x 1" x 1" | 152-H7H4 | 2" | 1" | 2.75" | 1.44" | 4.1 | |

Submitted by: