

Cambridge Brass
P.O. Box 249
140 Orion Place
Cambridge, Ontario
Canada N1R 5V1
Tel: (519) 621-5520
Fax: (519) 621-8674
http://www.cambridgebrass.com

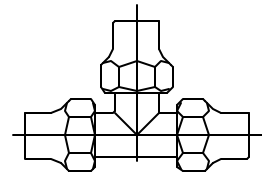

MODEL NO. 150

COPPER FLARE x
COPPER FLARE x COPPER FLARE

SERVICE TEE

FOR COPPER TUBING

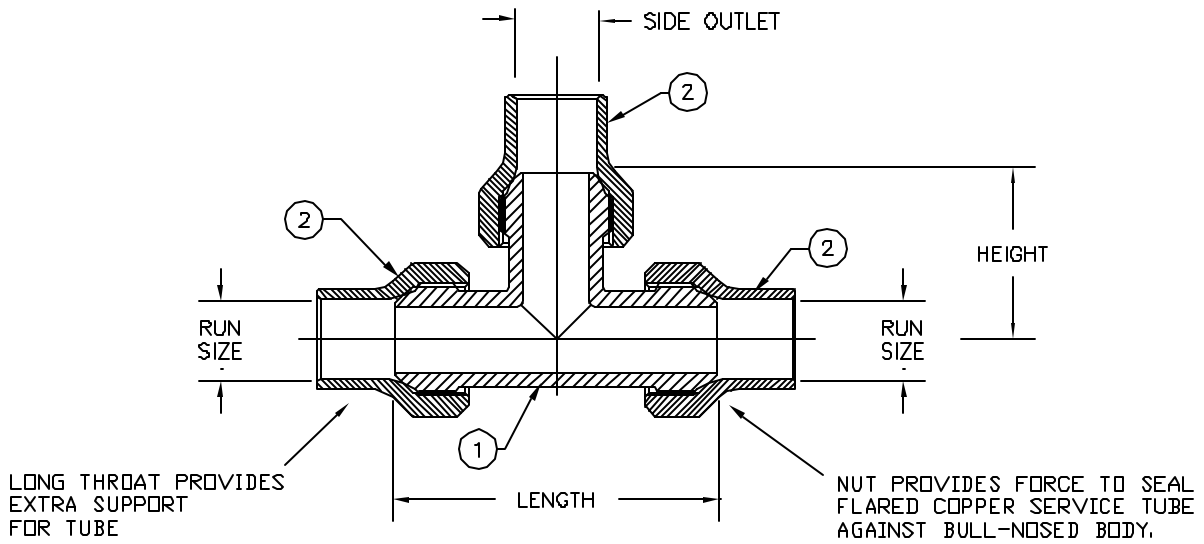

- PARTS AND MATERIAL:
1. TEE BODY: CAST BRASS, ALLOY C83600
2. NUT: CAST BRASS, ALLOY C83600

FEATURES:
- MANUFACTURED IN COMPLIANCE WITH AWWA STANDARD C800-05 (ASTM B-62 AND ASTM B584, UNS NO C83600-B5-5-5-5).
- CSA CLASSIFIED TO ANSI/NSF STANDARD 61-8.

Cambridge Brass considers the information in this submittal form to be correct at the time of publication. Item and option availability, including specifications, are subject to change without notice.

| TEE SIZE | CATALOG No. | RUN (BOTH ENDS) | SIDE OUTLET | LENGTH | HEIGHT | APPROX. WT. LBS. |
|------------------|-------------|-----------------|-------------|--------|--------|------------------|
| 3/4"x 3/4"x 3/4" | 150-C3C3 | 3/4" | 3/4" | 3.62" | 1.87" | |
| 1"x 1"x 1" | 150-C4C4 | 1" | 1" | 5.10" | 2.55" | |

Submitted by: