

Cambridge Brass
P.O. Box 249
140 Orion Place
Cambridge, Ontario
Canada N1R 5V1
Tel: (519) 621-5520
Fax: (519) 621-8674
http://www.cambridgebrass.com

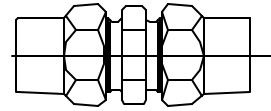

MODEL NO. 118

GRIP JOINT x GRIP JOINT

COUPLING

FOR COPPER OR PLASTIC (CTS) TUBING

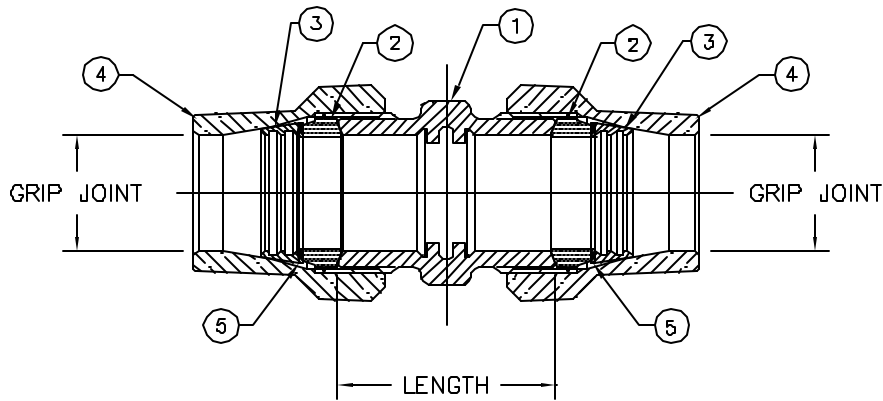

PARTS AND MATERIAL:

1. COUPLING BODY: CAST BRASS, ALLOY C83600
2. GASKET: NITRILE RUBBER
3. GRIPPER: BRASS, ALLOY C26000
4. GRIP JOINT NUT: CAST BRASS, ALLOY C83600
5. WASHER: POLYETHYLENE

FEATURES:

- MANUFACTURED IN COMPLIANCE WITH AWWA STANDARD C800-05 (ASTM B-62 AND ASTM B-584, UNS NO C83600-85-5-5-5).
- CSA CLASSIFIED TO ANSI/NSF STANDARD 61-8.
- BODY DESIGN PROVIDES LARGE RUGGED WRENCH FLATES FOR PROPER INSTALLATION.
- INTERNAL TUBE STOPS.

Cambridge Brass considers the information in this submittal form to be correct at the time of publication. Item and option availability, including specifications, are subject to change without notice.

CATALOG NO.	GRIP JOINT	GRIP JOINT	LENGTH	APPROX. WT. LBS.
118-GJ3GJ3	3/4"	3/4"	1.70"	
118-GJ4GJ3	1"	3/4"	2.10"	
118-GJ4GJ4	1"	1"	2.00"	

Submitted by: