

Cambridge Brass
P.O. Box 249
140 Orion Place
Cambridge, Ontario
Canada N1R 5V1
Tel: (519) 621-5520
Fax: (519) 621-8674
http://www.cambridgebrass.com

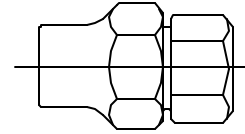

MODEL NO. 117

COPPER FLARE x
FEMALE COPPER FLARE

ADAPTOR

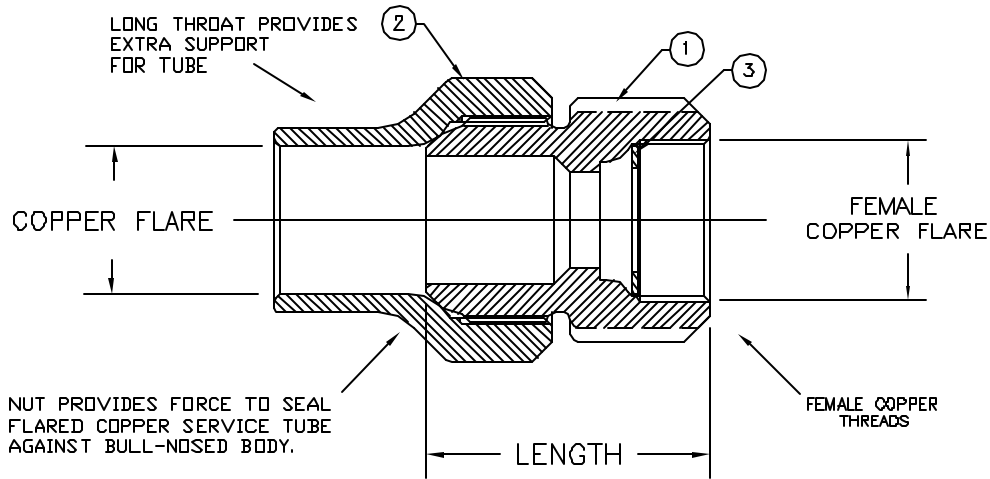

- PARTS AND MATERIAL:
1. BODY: CAST BRASS, ALLOY C83600
 2. COPPER FLARE NUT: CAST BRASS, ALLOY C83600
 3. SEALING WASHER: COPPER

- FEATURES:
- MANUFACTURED IN COMPLIANCE WITH AWWA STANDARD C800-05 (ASTM B-62 AND ASTM B-584, UNS NO C83600-85-5-5-5).
 - CSA CLASSIFIED TO ANSI/NSF STANDARD 61-8.
 - BODY PROVIDES LARGE, RUGGED WRENCH FLATES FOR PROPER INSTALLATION.

Cambridge Brass considers the information in this submittal form to be correct at the time of publication. Item and option availability, including specifications, are subject to change without notice.

CATALOG NO.	COPPER FLARE	FEMALE COPPER FLARE	LENGTH	APPROX. WT. LBS.
117-C3P4	3/4"	1"	2.19"	0.9
117-C4P3	1"	3/4"	2.22"	1.3

Submitted by: