

Cambridge Brass  
P.O. Box 249  
140 Orion Place  
Cambridge, Ontario  
Canada N1R 5V1  
Tel: (519) 621-5520  
Fax: (519) 621-8674  
http://www.cambridgebrass.com

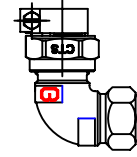

MODEL NO. 105NL

CAMPAK x FEMALE IRON PIPE

ELL COUPLING

CAMPAK FOR COPPER OR PLASTIC TUBING (CTS) BY THREADED PIPE

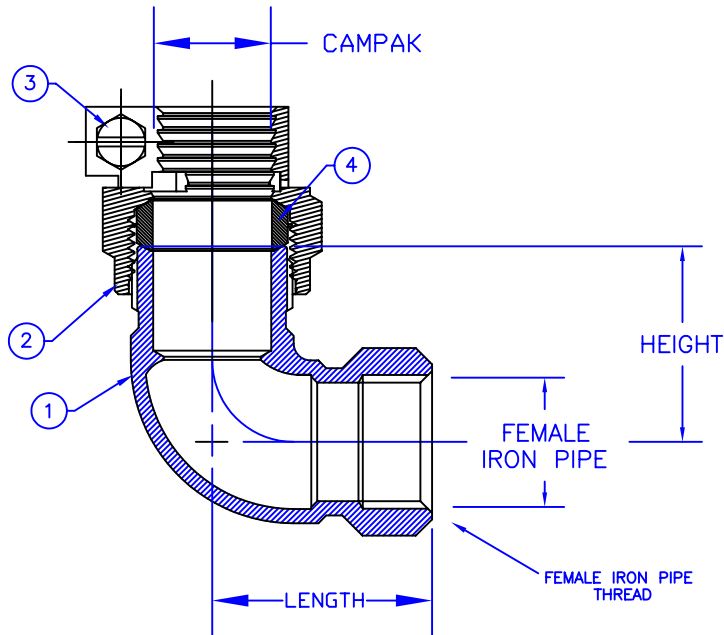

PARTS AND MATERIAL:

1. ELBOW BODY: CAST BRASS, ALLOY C89833
2. CAMPAK NUT: CAST BRASS, ALLOY C83600
3. SCREW: STAINLESS STEEL, ALLOY 304
4. COMPRESSION SEAL: NITRILE RUBBER

FEATURES:

- ALL COMPONENTS CONFORM TO AWWA C800-05 (ASTM B-584 UNS NO C89833 FOR BRASS PARTS IN CONTACT WITH POTABLE WATER, AND ASTM B-62 AND B-584 UNS NO C83600 FOR ALL OTHER BRASS PARTS).
- CSA CLASSIFIED TO ANSI/NSF STANDARD 61-8.

Cambridge Brass considers the information in this submittal form to be correct at the time of publication. Item and option availability, including specifications, are subject to change without notice.

ELL COUPLING SIZE	CATALOG NO.	CAMPAK	FEMALE IRON PIPE	LENGTH	HEIGHT	APPROX. WT. LBS.
3/4"	105NL-B3F3	3/4"	3/4"	1.69"	1.50"	0.8
1"	105NL-B4F4	1"	1"	1.97"	1.79"	1.4
1 1/2"	105NL-B6F6	1 1/2"	1 1/2"	2.60"	2.60"	3.3
2"	105NL-B7F7	2"	2"	3.14"	3.14"	5.3

Submitted by: